

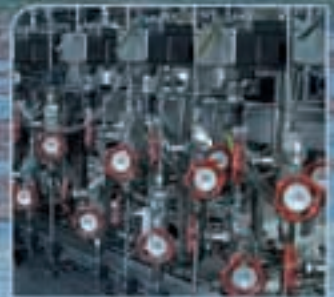

Nuclear power plant units Olkiluoto 1 and Olkiluoto 2



“Always as good as new”

Contents

TVO – A world-class nuclear power company	3
860 MW boiling water reactors OL1 and OL2	4
A cross-section of the OL1 and OL2	6
■ REACTOR PLANT	8
Reactor building	9
Reactor containment	11
Reactor	13
Reactor core and fuel	15
Control rods	19
Main circulation system	21
■ TURBINE PLANT	22
Turbines and generator	23
Condensate and feedwater	26
Sea water circuit	27
■ WATER CHEMISTRY	28
■ INSTRUMENTATION AND CONTROL SYSTEMS	30
■ ELECTRICAL POWER SYSTEMS	32
■ SAFETY	34
■ OFF-GAS SYSTEM	38
■ WASTE TREATMENT SYSTEMS	40
■ ELECTRICITY TRANSMISSION	42
■ TRAINING SIMULATOR	44
Technical data	46



TVO – a world-class nuclear power company

Teollisuuden Voima Oy (TVO) is a limited company founded in 1969. TVO generates electricity for its owners at cost price and builds new power generation capacity. TVO owns and operates the nuclear power plant at Olkiluoto.

Output from the nuclear power plant units at Olkiluoto is currently equal to about one sixth of the electricity consumed in Finland.

Solid nuclear power competence

TVO has a personnel of about 700. Personnel turnover is low, and those employees who have been with the company since the Olkiluoto power plant units went on stream have each accumulated up to 30 years of experience in their operation and maintenance.

Throughout its existence, TVO has trained its personnel to improve their nuclear power competence. The company follows current trends in the field by participating in international programmes on the development of reactor types, which have yielded up-to-date data and helped maintain contact with leading experts.

The company has also acquired nuclear power competence in the projects to uprate OL1 and OL2 and to modernize them, and other target-scale development and construction projects. The modernization projects have improved the safety, production capacity and economy of the power plant units.

At the top by international comparison

The capacity factors of the Olkiluoto power plant units, which are high even by international standards, testify to TVO's nuclear power competence. Ever since the early 1990s, the OL1 and OL2 capacity factors have remained between 93 % and 97 %, a tribute to their dependability.

This achievement is the result of careful, anticipatory planning of annual outages and modifications. The radiation doses received by personnel working at the Olkiluoto power plant are low by international comparison.

Doing things the TVO way

As a nuclear power company, TVO is committed to a high-level safety culture whose principles dictate that every matter is processed according to its safety implications and that a high level of reliability and production security are aimed for. Safety and its contributing factors always take priority over economic targets.

TVO's vision for the future is to remain a world-class nuclear power company that is highly valued by Finnish society. To this end, TVO pursues a responsible and proactive policy of continuous improvement in transparent cooperation with its interest groups.

860 MW boiling water reactors OL1 and OL2

The TVO nuclear power plant units, Olkiluoto 1 and Olkiluoto 2 (OL1 and OL2), are identical. Both have a boiling water reactor with a current net output of 860 MW.

The power plant units were supplied by AB Asea Atom of Sweden (today Westinghouse Electric Sweden AB), the first one on a turnkey basis and the second one with construction work undertaken by TVO.

The major subcontractors for the units were STAL-LAVAL Turbin AB (turbine plant), ASEA AB (electrical equipment, generator), Uddcomb Sweden AB (reactor pressure vessel), Finnatom (reactor internal parts, mechanical components), Oy Strömberg Ab (electrical equipment) and Atomirakennus (OL1 civil engineering consortium). The OL2 construction work was carried out by a Finnish-Swedish consortium, Jukola.

The OL1 unit was first connected to the national grid in September 1978, and the OL2 unit in February 1980.

There are seven main types of nuclear reactor in commercial use worldwide. Most of them are pressurized-water reactors or boiling-water reactors, collectively known as light-water reactors. In these, purified and demineralized water is used as both a coolant and moderator.

The most common type of reactor in the world is the pressurized-water reactor (PWR). More than 60 % of all nuclear reactors are PWRs. The runner-up is the boiling-water reactor (BWR), with a share of just over 20 %.

The other reactor types in common use are the pressurized heavy water reactor (PHWR), the gas-cooled reactor (Magnox), the advanced gas-cooled reactor with graphite moderator (AGR), the high-power channel reactor with graphite moderator, developed in the Soviet Union (RBMK), and the fast breeder reactor (FBR).

Nuclear power plants in commercial operation, year 2005

(source: World Nuclear Industry Handbook 2006)

Reactor type	Main Countries	Number	GWe	Fuel	Coolant	Moderator
Pressurised water reactor	US, France, Japan, Russia	268	249	enriched UO ₂	water	water
Boiling Water Reactor	US, Japan, Sweden	94	85	enriched UO ₂	water	water
Gas-cooled Reactor (Magnox & AGR)	UK	23	12	natural U, enriched UO ₂	CO ₂	graphite
Pressurised Heavy Water Reactor, "CANDU" (PHWR)	Canada	40	22	UO ₂	heavy water	heavy water
Light Water Graphite Reactor (RBMK)	Russia	12	12	enriched UO ₂	water	graphite
Fast Neutron Reactor	Japan, France, Russia	4	1	PuO ₂ and UO ₂	liquid sodium	none
Total		441	381			

Operating principle of the boiling water reactor

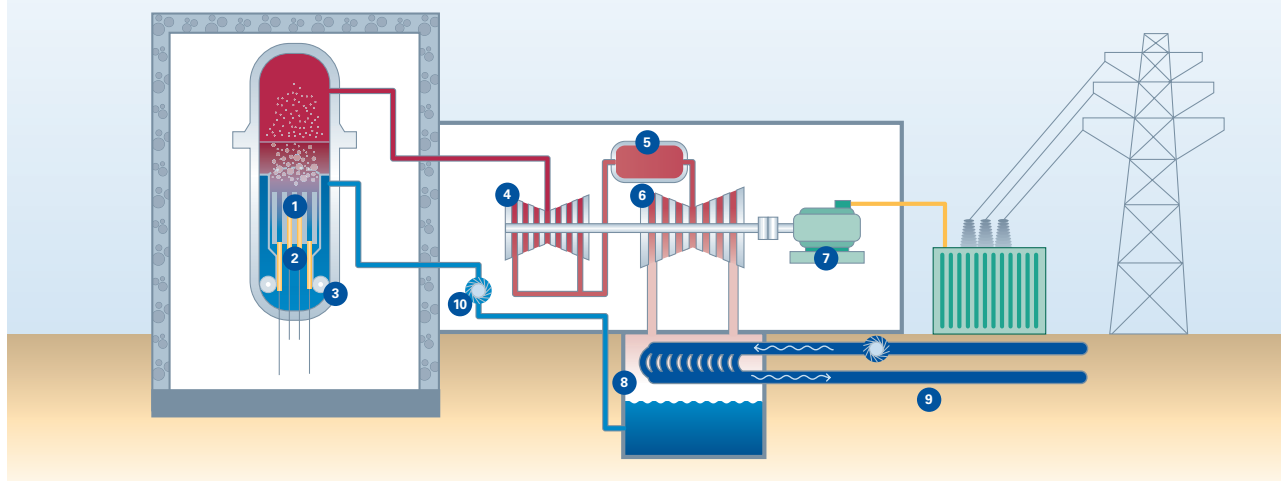

In a boiling water reactor, the water boils as it passes between the **fuel rods (1)** in the reactor. The reactor output is regulated with **control rods (2)** and the **recirculation pumps (3)**. The steam generated in the reactor is transferred to the **high-pressure (HP) turbine (4)** through the main steam lines. Having expended part of its energy in the HP turbine, the steam is then transferred to the **reheaters (5)**, where it is dried and superheated and then transferred to the **low-pressure (LP) turbines (6)**. All the turbines are coaxially

connected to the **generator (7)**, which generates electricity that is then fed into the national grid. The steam exiting the LP turbines is condensed into water in the **condenser (8)**, using **sea water (9)** as coolant. The condensed water is conveyed through preheaters and a clean-up system to the **feedwater pumps (10)**, which feed the water back into the reactor. The heated cooling water is pumped back into the sea.

Always as good as new

TVO pursues a long-term, careful schedule of maintenance to keep the OL1 and OL2 units in a condition always as good as new. They are also systematically upgraded to match current requirements. Both the Olkiluoto units undergo a maintenance outage and a refuelling outage in alternative years. The longer maintenance outage lasts some two weeks. Maintenance outage involves refuelling, scheduled inspections, anticipatory maintenance and repairs, and also major modification and modernization work and inspection of the condition of the power plant unit. The refuelling outage is a short, compact outage with as little modification work done as possible.

In addition to this schedule, both units undergo a longer, extensive service outage roughly every ten years to allow for major modifications.

Between 1995 and 1998, both units were the focus of an extensive modernization programme (MODE), which involved some 40 major projects. In both units, the steam separator, generator and main transformer were changed; the internal components of the low-pressure turbines and the turbine control and protection system were replaced; and the high-pressure turbine was modified.

The Turbine Island Modernisation project (TIMO), timed to coincide with the annual outages in 2005-2006, continued the modernization of the turbine plant with the replacement of the reheaters, high-pressure turbines, steam dryers and 6.6 kV switchgear plant and the modernization of turbine process automation in both power plant units.

Modernization and modification projects

<i>Modernization and reactor uprating, electrical output from 660 MW to 710 MW</i>	<i>1983 – 1984</i>
<i>Construction of interim storage facility for spent fuel (KPA storage)</i>	<i>1984 – 1987</i>
<i>Containment filtered venting system (SAM)</i>	<i>1986 – 1989</i>
<i>Plant-identical training simulator at Olkiluoto</i>	<i>1988 – 1990</i>
<i>Construction of final repository for low- and intermediate-level radioactive waste (VLJ cave)</i>	<i>1988 – 1992</i>
<i>Modernization programme (MODE) and reactor uprating, electrical output from 710 MW to 840 MW</i>	<i>1995 – 1998</i>
<i>Turbine plant modernization (TIMO), electrical output from 840 MW to 860 MW</i>	<i>2005 – 2006</i>

A Cross-section of the OL1 and OL2

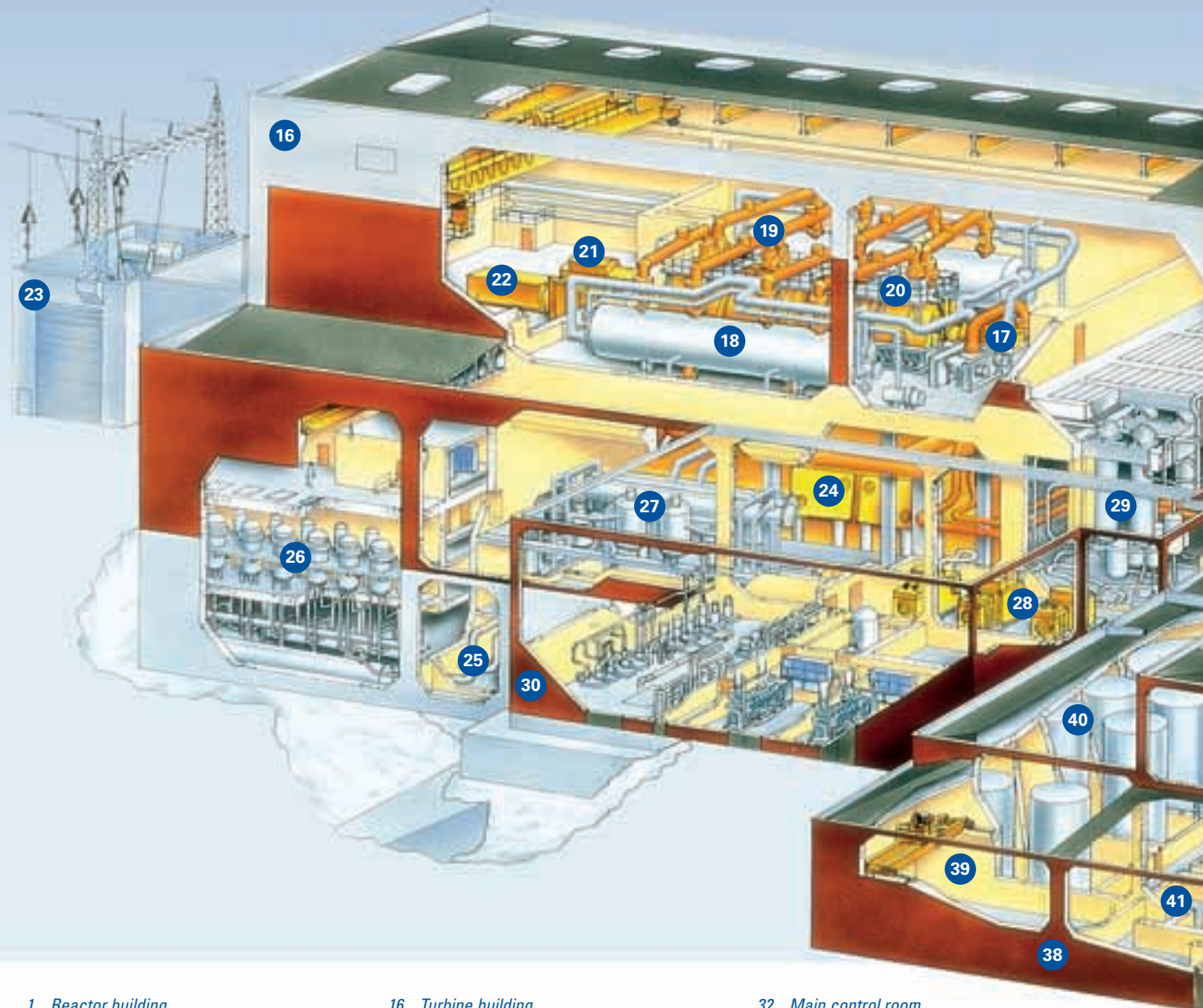

- | | | |
|---|------------------------------------|---|
| 1. Reactor building | 16. Turbine building | 32. Main control room |
| 2. Reactor pressure vessel | 17. High pressure turbine | 33. Entrance building |
| 3. Recirculation pumps | 18. Reheater | 34. Lift |
| 4. Control rod drives | 19. Cross-over pipes | 35. Ventilation stack |
| 5. Reactor pressure vessel cover | 20. Low pressure turbines | 36. SAM scrubber (filtered venting system of the containment) |
| 6. Containment cover | 21. Generator | 37. Active workshop/laboratory building (only OL1) |
| 7. Containment cover lifted off (during annual outages) | 22. Exciter | 38. Radioactive waste building |
| 8. Main steam lines | 23. Main transformer | 39. Low and medium-level radioactive waste storage |
| 9. Reactor service bridge | 24. Condenser | 40. Liquid waste storage tanks |
| 10. Reactor pool | 25. Condensate line | 41. Solid waste system |
| 11. Fuel pool | 26. Condensate purification system | 42. Make-up water tank |
| 12. Upper dry-well of containment | 27. Low pressure preheaters | |
| 13. Lower dry-well of containment | 28. Feedwater pumps | |
| 14. Condensation pool of containment | 29. High pressure preheaters | |
| 15. Main steam lines | 30. Auxiliary systems building | |
| | 31. Control building | |

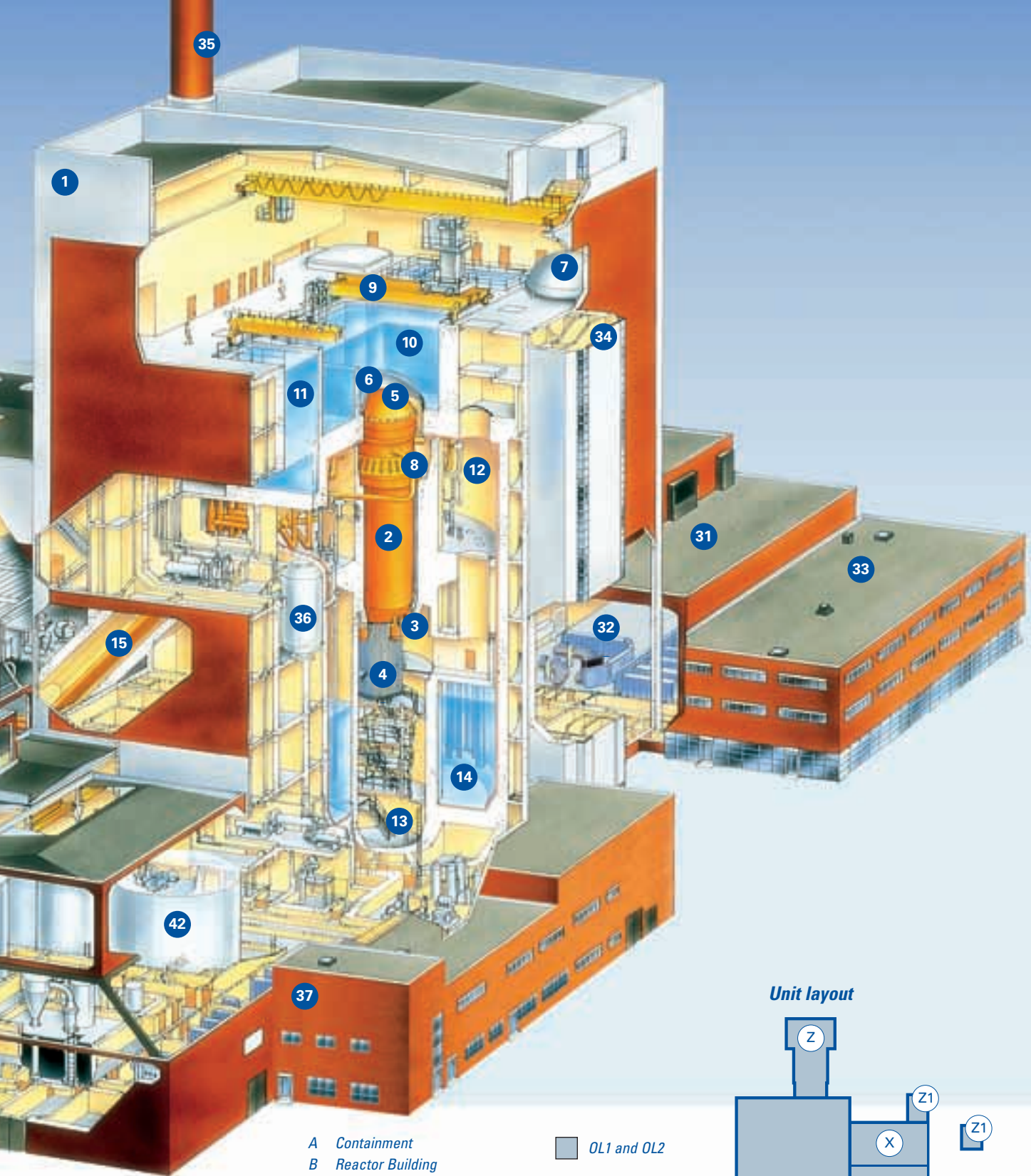

- A Containment
- B Reactor Building
- D Turbine building
- E Main control room
- F Radioactive waste building
- H Auxiliary buildings
- N Active workshop/laboratory building (only OL1)
- P Entrance building
- T Cooling water supply
- X Switchgear
- Z Main transformer
- Z1 Startup transformers

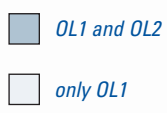

Unit layout

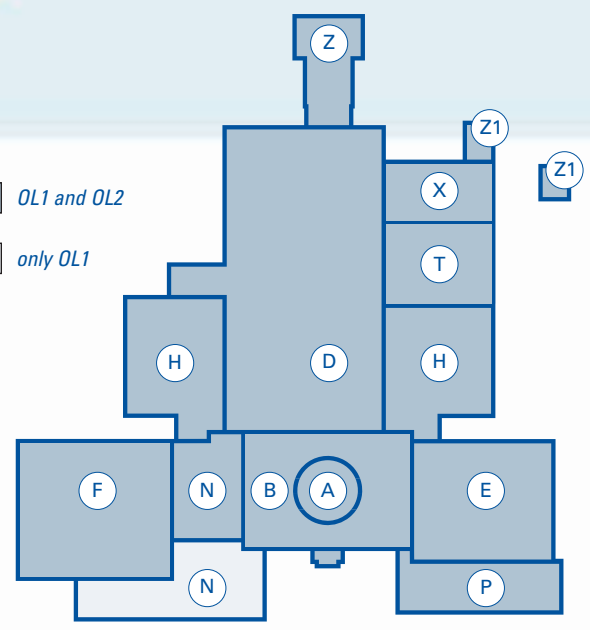

REACTOR PLANT

The reactor building encloses the containment of the reactor, which in turn contains the reactor pressure vessel. The reactor cores of OL1 and OL2 contain 500 fuel assemblies each. The output of the reactor is regulated with control rods and the recirculation pumps.

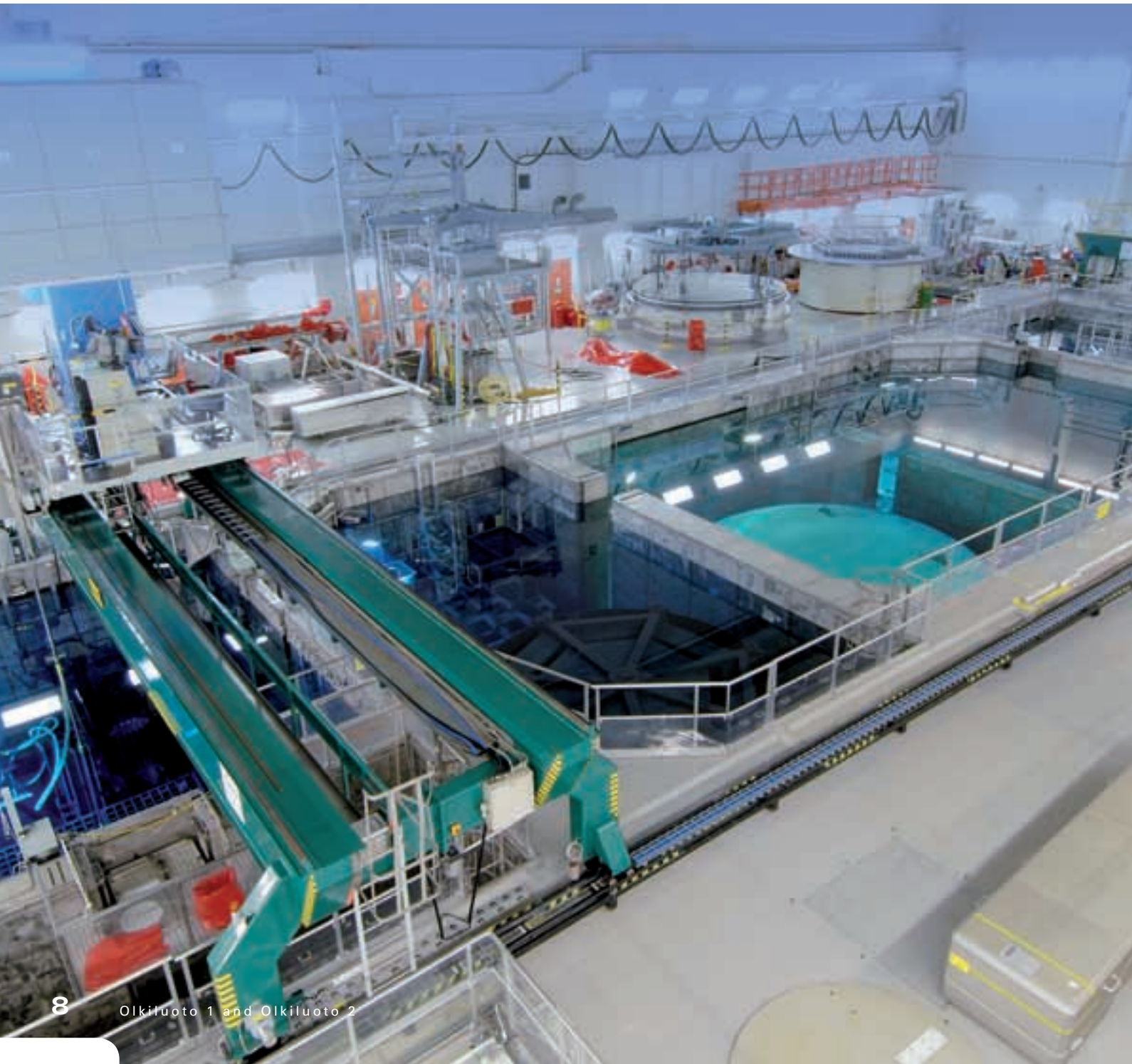

Reactor building

The reactor building is the highest and most dominant building of the plant units. It encloses the containment of the reactor.

The reactor building serves as a secondary containment. The reactor hall, at the top of the building, contains the reactor pool and fuel pools with storage racks and pools for reactor internals, the reactor service bridge for refuelling operations, and the overhead crane for handling the containment cover, the reactor vessel cover and other heavy components.

Dry storage facilities for receiving and storing fresh fuel are located at floor level below the reactor hall.

The bottom part of the reactor building contains separate compartments for important, safety-related systems, such as the emergency cooling systems.

Physical separation

At the Olkiluoto power plant units the safety-related systems are divided into four redundancy systems (A, B, C and D) that are separated from one another. Systematic separation provides effective built-in protection against the hazards associated with fires, flooding, crashing aircraft and other external impacts.

The redundancy circuits of safety-related systems in the Olkiluoto plant unit are assigned to two main groups, which are located in physically separated areas. A separation by distance or by means of barriers is used between the redundancy systems (A/C and B/D, respectively). This principle is also applied to the electric power supply and the control equipment. Areas housing equipment belonging to different redundancy groups are ventilated and cooled by separate ventilation subsystems.

Cross-section of the reactor building and the containment

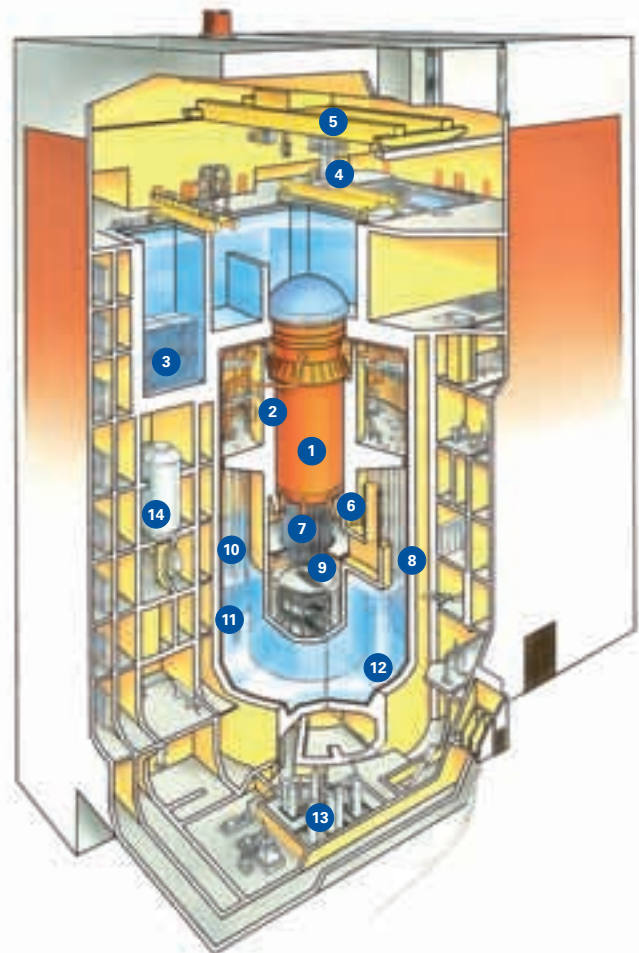

- | | |
|----------------------------|---------------------------------|
| 1. Reactor pressure vessel | 8. Containment |
| 2. Main steam lines | 9. Control rod service platform |
| 3. Fuel pool | 10. Blow-down pipes |
| 4. Reactor service bridge | 11. Embedded steel liner |
| 5. Reactor hall crane | 12. Condensation pool |
| 6. Recirculation pumps | 13. Scram system tracks |
| 7. Control rod drives | 14. SAM-scrubber |

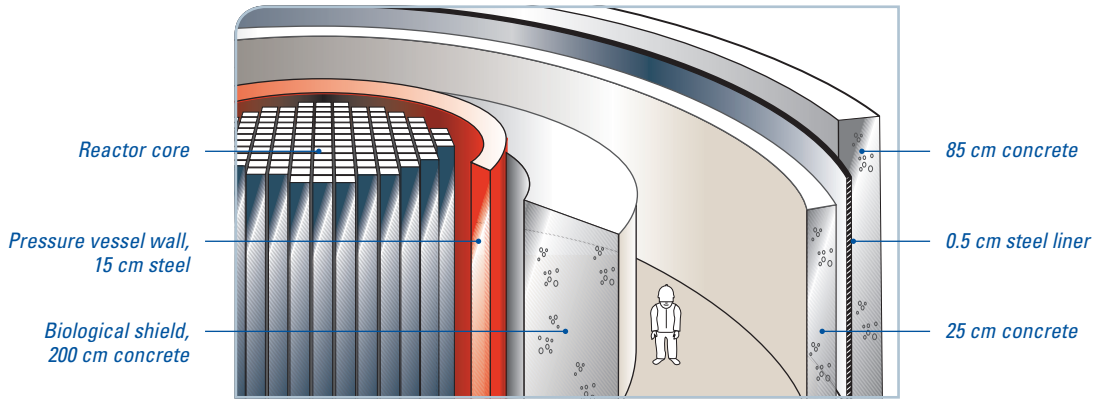

The reactor pressure vessel is enclosed in a containment made of concrete and steel.

Containment

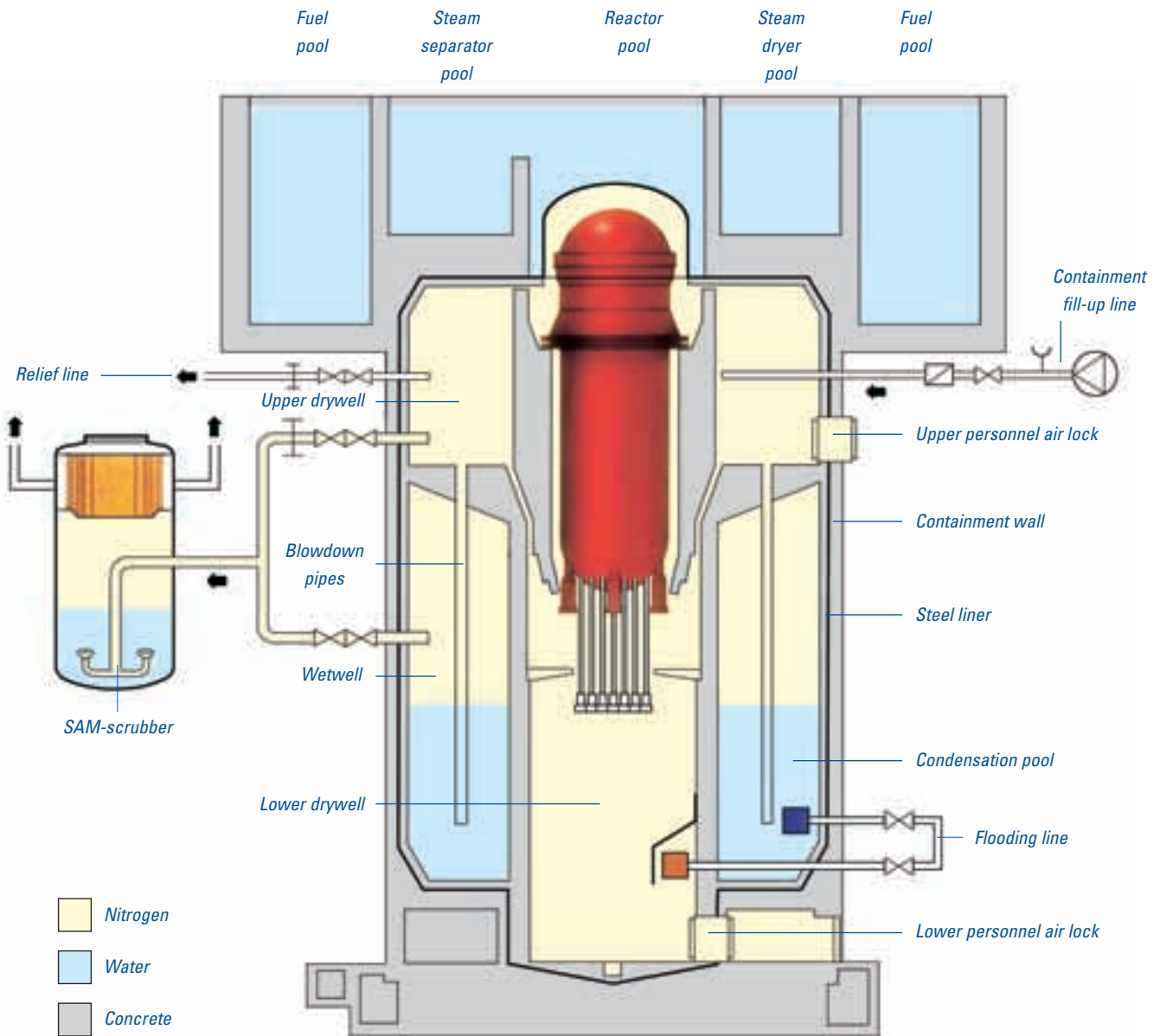

Reactor containment

The reactor containment is made of prestressed concrete. The containment is based on the principle of pressure-suppression. This allows for a compact containment design, with the minimum amount of equipment installed inside the containment.

The use of internal main circulation pumps has allowed a further reduction of the containment volume. All components requiring regular servicing during the normal operation of the reactor are located outside the containment.

The tightness of the containment is ensured by a steel liner embedded in the concrete and the steel cover of the containment. The concrete protects the steel liner against corrosion, thermal transients and hot water and any steam jets or missiles that may occur in the event of a pipe rupture.

The tightness of the containment vessel is checked regularly, every fourth year. When the plant unit is in operation the containment is filled with inert gas. Furthermore, the design incorporates permanently installed systems for recombination of hydrogen and oxygen that prevent the accumulation of dangerous combustible gas mixtures inside the containment following an accidental loss of coolant. The containment is divided into the upper and lower drywell, and the wetwell.

Access to the containment is gained through air locks at the bottom of the lower drywell, and at the floor of the upper drywell. The cylindrical part of the containment extends to the top of the reactor pressure vessel. The slip forming technique was extensively used in construction.

The condensation pool is enclosed in the annular space between the containment wall and an inner cylindrical wall. The inner wall also carries the biological shield of the reactor, i.e. the concrete wall enclosing the reactor pressure vessel.

Vent pipes extend vertically from the upper drywell to the condensation pool. Steam from possible ruptures and leaks in the reactor's primary systems are condensed in the pool. Steam from reactor relief valve discharges is blown into the pool through blow-down pipes from each

valve. A relief line with rupture disc activation is provided to exclude the possibility of a rapid containment failure in the case of pressure suppression bypass. There is a scrubber unit (SAM) for the containment gas cleanup to relieve the containment pressure following a severe accident. The lower drywell can be flooded by opening lines from the wetwell pool. A line is provided to fill the containment with water from an outside source.

*The reactor steel cover is fixed with 120 bolts.
The cover is sealed with O-ring seals.*



Reactor pressure vessel

Inner diameter	mm	5,540
Inner height	mm	20,593
Wall thickness, carbon steel (ASME A533B, A508Gr2)	mm	134
Thickness of stainless steel liner	mm	5
Design pressure	bar	85
Operation pressure	bar	70
Design temperature	°C	300
Operation temperature	°C	286
Weight of vessel	ton	524
Weight of cover	ton	107

Sectional view of the reactor pressure vessel

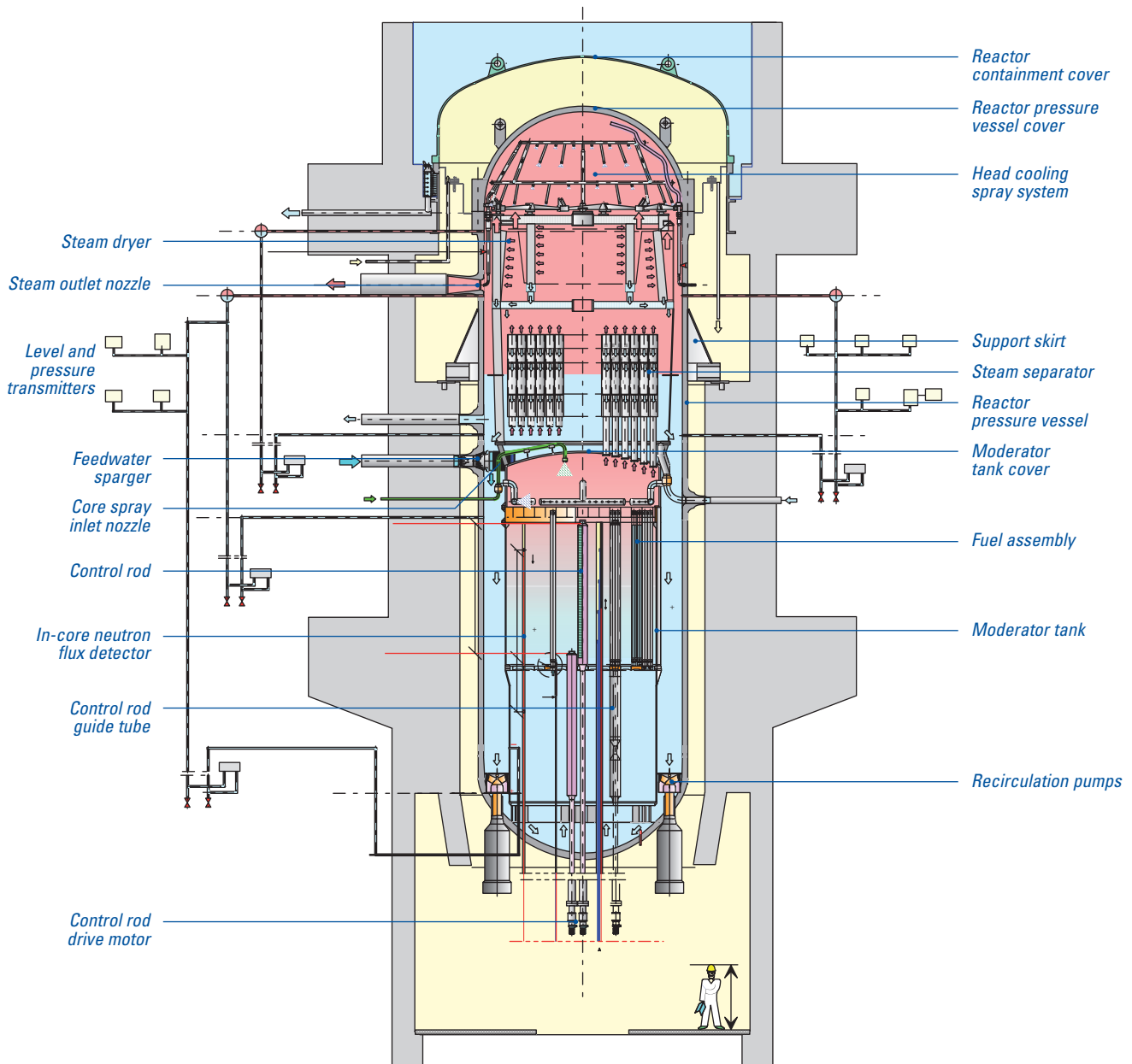

The reactor pressure vessel is made of low-alloy steel, with a lining of stainless steel. All major pipe nozzles are located above the top of the core, to ensure that the core is kept flooded in the event of pipe damage in the primary systems. The reactor vessel hangs on top of the biological shield by means of a welded-on support skirt.

The vessel support skirt is located near the primary system pipe connections – this minimizes stress on the pipe caused by the thermal expansion of the vessel. This location also gives more space to carry out the maintenance of the recirculation pumps.

The reactor internals are designed to allow for fast and safe handling during refuelling operations. Apart from the moderator tank support skirt and the pump deck, which are welded to the reactor vessel, all the internals are removable.

The internals are held in position in the reactor vessel by means of resilient beams in the reactor vessel cover. When the cover has been removed, the internals can be lifted out of the reactor without breaking any bolted joints.

Another related feature is that the thermal insulation of the reactor cover is fastened to the inside of the containment cover, and is removed together with it when the reactor is to be opened.

All external pipe connections to the reactor cover have been eliminated by fixing the connections to the reactor pressure vessel, which means that the procedures for removing the reactor pressure vessel cover have been considerably simplified.

The reactor pressure vessel seen from above. The bolt holes for the pressure vessel cover on the flange of the pressure vessel are sealed with plugs. The containment seal surrounds the pressure vessel cover, and the flange for attaching the containment cover is outermost.



Servicing the bolts of the reactor pressure vessel cover.



Core

Number of fuel assemblies	500	
Total fuel weight	tnU	85–90
Core diameter (equiv.)	mm	3,880
Core height	mm	3,680

Fuel

Fuel rods per assembly	91–96	
Fuel rod outer diameter	mm	approx. 10
Cladding material	Zry-2	
Weight of fuel assembly (incl. channels)	kg	approx. 300
Uranium fuel per assembly	kgU	175

The structure of GE-14 type fuel assembly

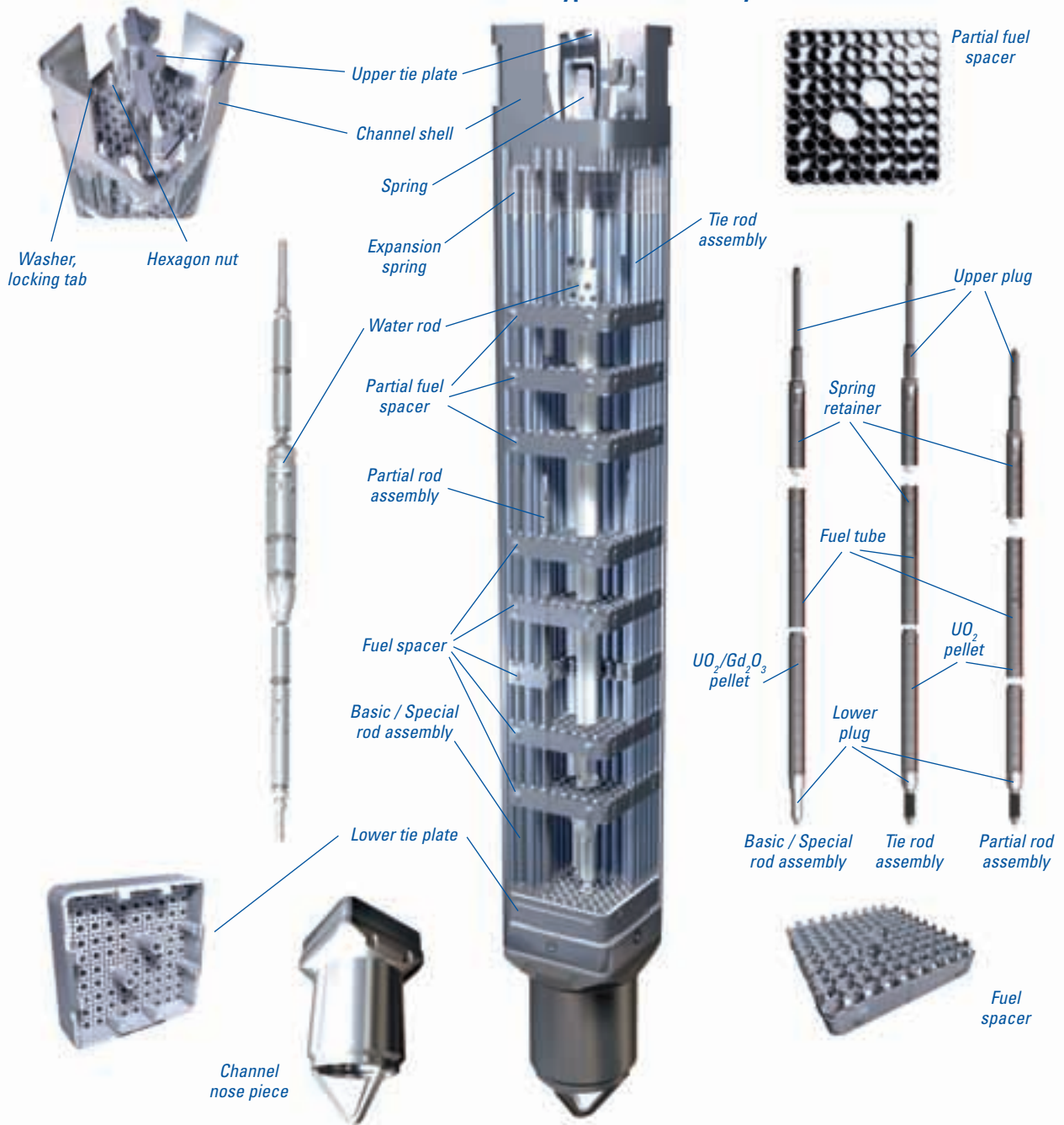

Reactor core and fuel

The reactor cores of the OL1 and OL2 power plant units contain 500 fuel assemblies each. The fuel bundles are put in fuel channels, which convey the coolant around the fuel rods.

Initially designed as an 8 x 8 matrix, the fuel assemblies were first redesigned as a 9 x 9 matrix and then as the 10 x 10 matrix currently in use. The 10 x 10 type has new features that have made reactor power uprating and more efficient fuel use possible.

Compared with TVO's earlier fuel designs, 10 x 10 fuel has lower linear heat generation rate in the fuel rods, and this fuel type improves the heat transfer from fuel to coolant. The 10 x 10 assemblies also contain different assembly-internal water structures such as water channels, which improve reactor core behaviour at high power levels and in case of malfunctions. In addition to the water channels, the assemblies contain partial-length fuel rods that improve reactor stability.

The uranium fuel is in the form of short sintered pellets made of UO_2 . The pellets contain uranium whose U235 content is enriched. The pellets are charged in Zircaloy-2 tubes which are welded with end plugs to constitute hermetically closed fuel rods. The rods are assembled by means of upper and lower tie plates and 6-8 spacers. The geometrical structure of the assembly depends on the design.

A burnable absorber (Gd_2O_3) is used in the fuel design, added to some of the pellets in the bundle to reduce the power peaking factor and to compensate for the excess reactivity during the first half of an operating cycle.

The fuel assemblies have radially-zoned enrichment distribution. In this way, the power-peaking factor can be reduced and fuel heat transfer capacity optimized.

In the figure below, enrichment is colour-coded: the darker the colour, the higher the enrichment.

Slightly under one quarter of the fuel in the reactor is replaced with fresh fuel annually. In this photo, the fresh fuel assemblies can be identified by their lighter colour.

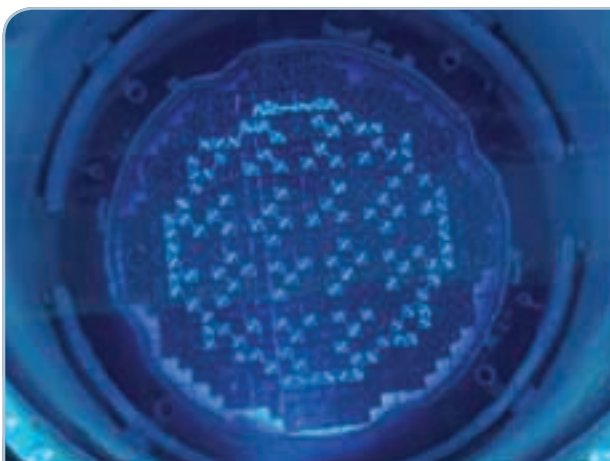

GE14 fuel assembly

- ⊙ Water rod
- ⊙ Rod with gadolinium
- ⊙ Partial-length fuel rod

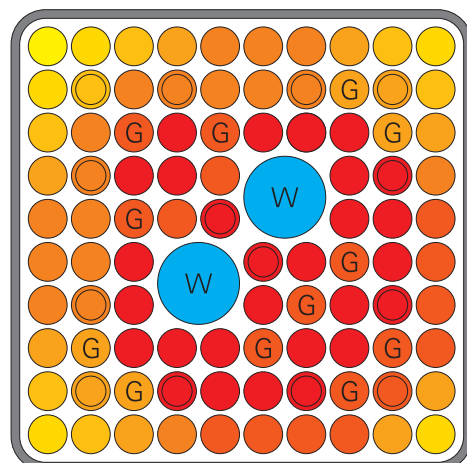

Regulating reactivity

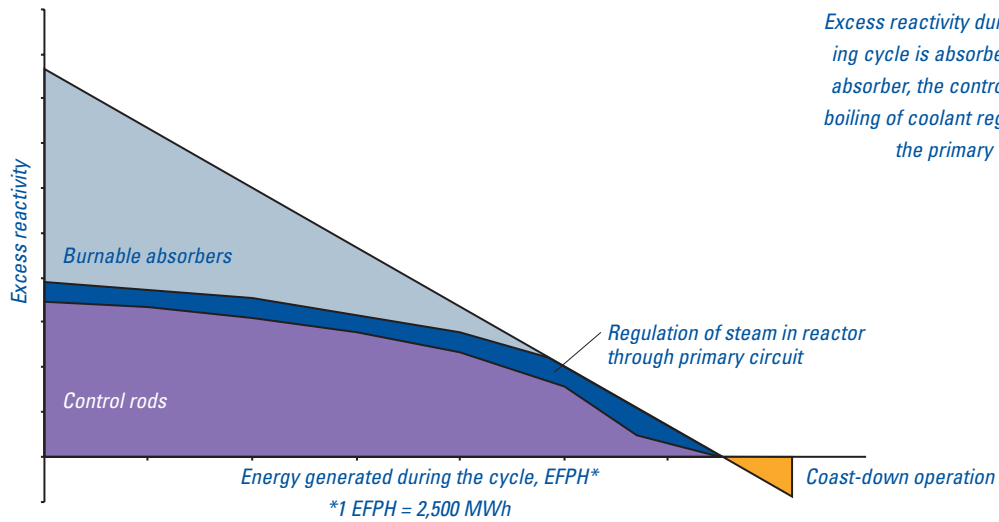

Excess reactivity during the operating cycle is absorbed by burnable absorber, the control rods and the boiling of coolant regulated through the primary circuit.

Refuelling

When a reactor is operated in a one-year cycle, typically some one quarter of the fuel assemblies in the reactor core are replaced during each cycle. The amount of fuel replaced is determined by its excess reactivity, which corresponds to the energy to be generated during the cycle, i.e. the cycle length. Fuel assemblies with different char-

acteristics are placed in the reactor so that the restrictions on core use and fuel use are complied with. Every year, a reactor physical measurement of the fuel assemblies determines the U235 enrichment level of the fuel rods in the refuelling batch and burnable neutron absorber content and placement, taking into account the anticipated length of future cycles.

Spent fuel assemblies are transferred from the reactor to the fuel pool using the reactor service bridge.



Reactor use and regulation

During the operating cycle, excess reactivity in the reactor is absorbed by the control rods in the reactor core, by the burnable absorber in the fuel assemblies, and by the boiling of the coolant regulated through the primary circuit. Excessive reactivity is at its highest at the beginning of the cycle and steadily decreases as the burnable absorber is consumed, which reduces the need for moving the control rods at various points of the cycle. Once the burnable absorber has been sufficiently consumed, reactivity required for power generation can be released by retracting the control rods in small increments. At the end of the cycle, all the control rods are fully retracted, and reactivity is maintained for a while by increasing the primary circuit flow until the reactor output slowly begins to decline.

The control rods are used not only for regulating reactivity but also for adjusting the power distribution in the reactor core and for regulating the output of the reactor. Minor power adjustments are made by regulating the primary circuit flow.

Interim storage of spent fuel

Fuel assemblies removed from the reactor are transferred to fuel pools in the reactor hall to cool off for a few years. The water in the pools cools the fuel and protects the environment against radiation. During this process, the radioactivity of the spent fuel is considerably reduced. The fuel assemblies are kept under water throughout the entire transfer.

After a few years of cooling, the fuel assemblies are packed into a strong, water-filled transfer tank and trans-

ported by a special vehicle to the interim storage facility (KPA storage) at the power plant site. The transfer tank can hold 41 fuel assemblies and weighs 93 tonnes when fully loaded.

Before placement in the final repository, the spent fuel is kept in water-filled pools in the interim storage facility for several decades. During this time, the radioactivity and heat output of the spent fuel decrease to less

than 1/1000 of the original levels, which makes it easier to pack and handle the waste.

The final repository will be at Olkiluoto. Its construction and operation will be the responsibility of Posiva Oy, a company jointly owned by TVO and Fortum Power and Heat Oy. The spent fuel from the Fortum's nuclear power plant units in Loviisa will also be stored at Olkiluoto. Final depositing is scheduled to begin in 2020.

Spent fuel is transferred to the interim storage facility in a transfer tank made of spheroidal graphite cast iron. Its walls are 36 cm thick, and it weighs 93 tonnes when fully loaded.



Control rods

Number of control rods		121
Absorber length	mm	3,650
Total length	mm	6,380
Absorber material		B ₄ C and Hf

Control rod drives

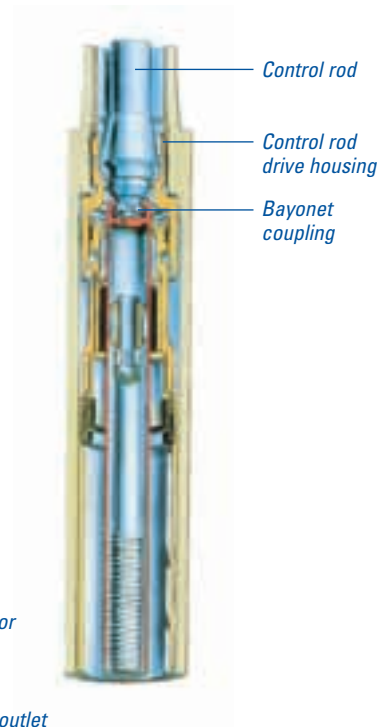
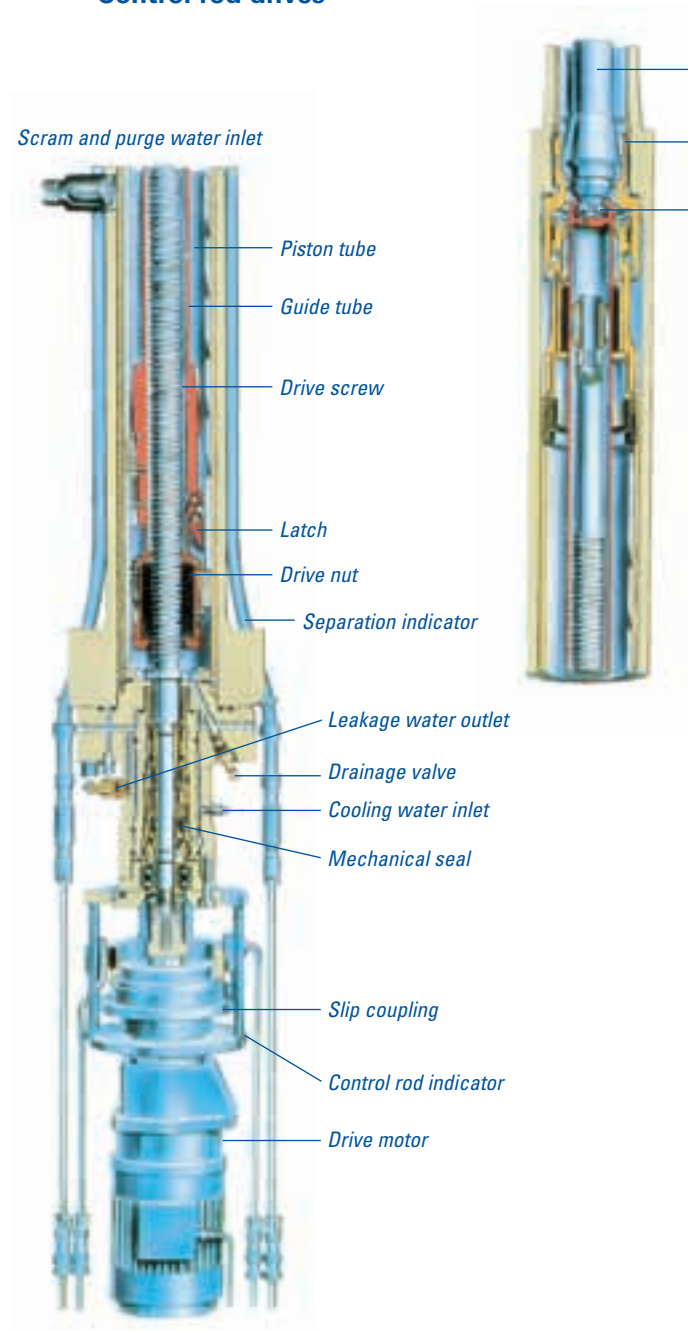
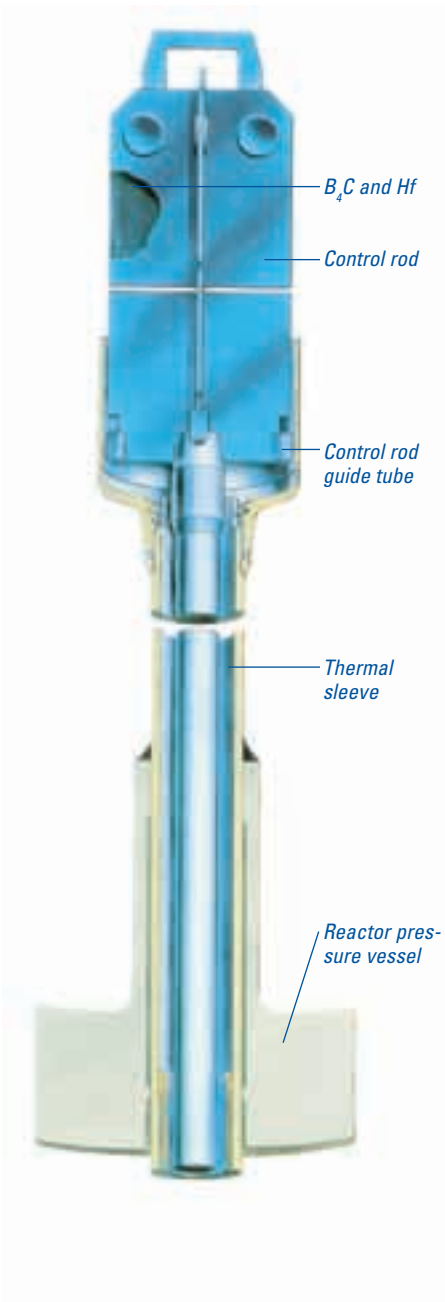

Control rods

The control rod drive system provides two independent ways of moving the control rods, one electro-mechanical system for normal operation with fine motion and one hydraulic system for fast scram insertion.

The drive allows for slow-motion and accurate positioning of the control rods. The fine-motion feature enables control rod manoeuvring even at full power without increasing the risk of mechanical interaction between pellets and cladding.

The controllability of the plant is improved by the ability to move a synchronized group of control rods. The power supply to the electro-mechanical drives is provided by four diesel-backed busbars.

The control rod drives are purged with water from the reactor water cleanup system to keep the gaps clean to minimize radioactive contamination and thereby reduce occupational exposure during maintenance.

The drives provide rapid insertion of the control rods by means of high-pressure water acting on a piston tube.

The control rods are divided into 14 scram groups of eight or nine rods each. Each scram group is served by a scram module, comprising a water tank connected to a nitrogen container (with high pressure nitrogen) through a scram valve.

The division into scram groups is made so that the reactivity coupling between the rods within a scram group is negligible. Due to this arrangement, the malfunction of one scram group is equivalent to the loss of one control rod.

Furthermore, the electricity power supply to the scram system and the electromechanical drives are arranged in such a way that an electrical fault cannot simultaneously render both the scram function and the electro-mechanical drive inoperative. An automatic boron injection system is provided to shut down the reactor in the event of a total failure of the control rod insertion.

The control rods are divided into 14 scram groups, five of eight rods each and nine of nine rods each. There are 121 control rods in all in the reactor core.

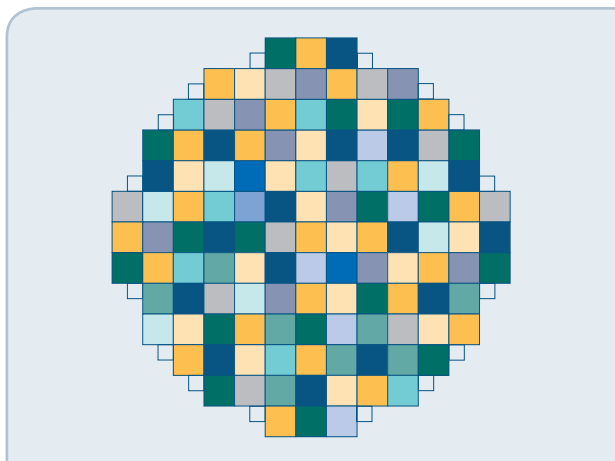

The drive screw and drive nut of the control rod drive being serviced during the annual outage.



Recirculation pump

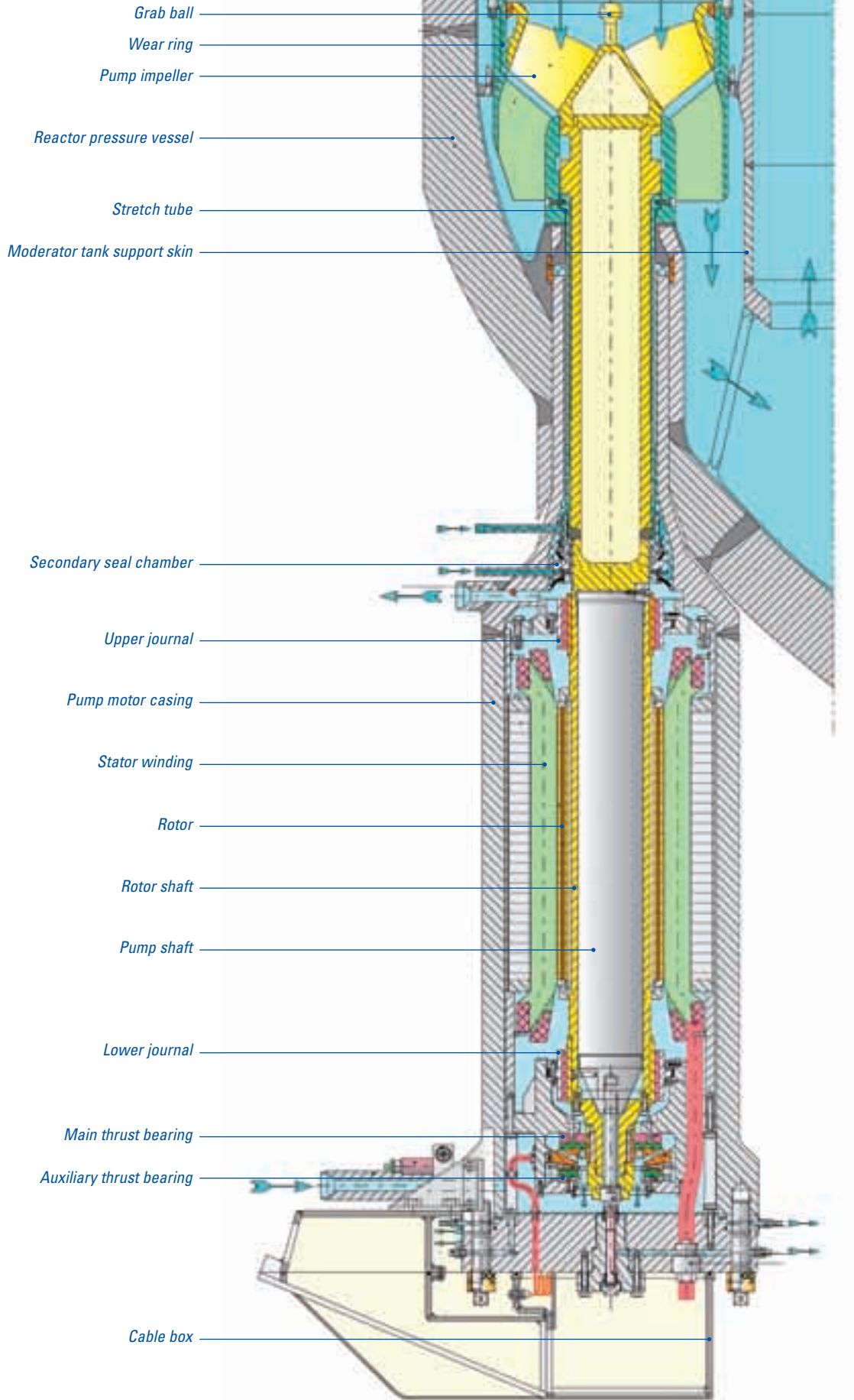

Main circulation system

The primary circuit is a water circulation system within the reactor pressure vessel. The water flows down onto the bottom of the vessel and is pumped up in the middle, through the reactor core. The water cools the core. Steam to the turbines is generated as part of the water boils.

The coolant flow through the core is maintained by six internal circulation pumps. The internal circulation pump design is based on wet motors, thus eliminating shaft seals. The motor housing forms an integral part of the reactor vessel. Internal circulation pumps provide a number of advantages over external pumps:

- no risk of major pipe rupture below the top of the core
- compact containment design
- low circulation pressure drop improves natural circulation and decreases auxiliary power demand
- reduced radiation level of the drywell contributes to very low occupational exposure during pump motor maintenance and inspection
- significant reduction of primary system weld length

A split shaft design allows for convenient assembly and disassembly. The pump shaft extends into the hollow motor shaft and power is transmitted from the motor shaft through a coupling that can be disassembled from the bottom of the motor housing. A pump motor or impeller can thus be removed or replaced without draining the water from the reactor vessel.

Recirculation pump (Normal power operation, 6 pumps)

Rated speed	rpm	approx. 1,350
Head	m	approx. 25
Motor power	kW	740

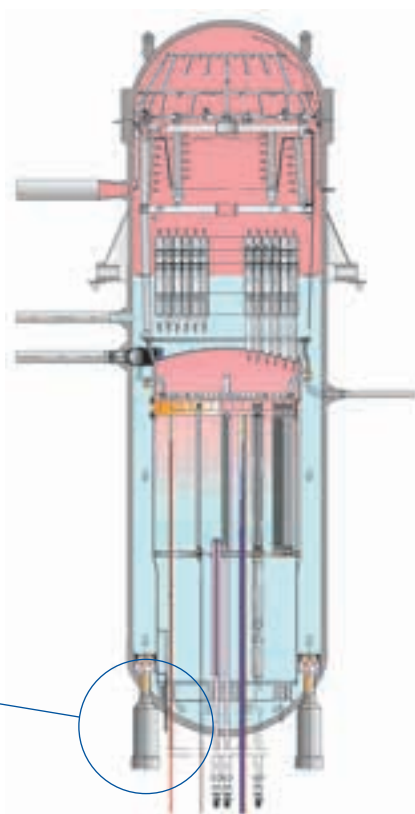

TURBINE PLANT

The steam generated in the reactor is transferred to the high-pressure (HP) turbine through the main steam lines. Having expended part of its energy in the HP turbine, the steam is then transferred to the reheaters, where it is dried and superheated and then transferred to the low-pressure (LP) turbines. All the turbines are coaxially connected to the generator, which generates electricity that is then fed into the national grid. The steam exiting the LP turbines is condensed into water in the condenser, using sea water as coolant.



Turbine plant

Live steam is transferred from the reactor to the High Pressure (HP) turbine through four main steam lines, with a control valve and an emergency stop valve built into the same casing.

Exhaust steam from the HP turbine is discharged via transfer pipes into two consecutive combined moisture separators and steam reheaters, located one on each side of the turbine. The reheating is done partly with HP turbine extraction and partly with live steam from the main steam lines. The reheated steam is supplied to the LP turbines through eight crossover pipes equipped with combined emergency stop and intercept valves. The HP and LP (Low Pressure) turbines are equipped with steam extraction for preheating the condensate and feedwater. The turbine plant also includes bypass valves for dumping steam directly into the condenser. This is used during plant startup and shutdown, and in the event of generator load loss.

HP turbine

The HP turbine is a double axial-flow, symmetrical, reaction type turbine with steam admission at the middle and exhaust at the ends. The main parts are:

- a welded outer casing
- a cast inner casing
- a forged and welded rotor
- shaft seals at the ends.

The turbine is of a dual casing type with both casings split horizontally on the turbine centre line, bolted together through a flanged joint.

Live steam is admitted into the inner casing through two central penetration ducts, in the upper and lower halves. In this way, live steam does not come into contact with the outer casing. Steam is extracted at one point on each side of the turbine through holes in the inner casing and led to the extraction space between the casings and then to the extraction ducts.

The outer casing is sealed off from the atmosphere of the turbine hall by double compensating bellows at the penetration ducts and by labyrinth-type shaft glands at the turbine shafts. The outer casing is built of plates and forgings welded together to form a cylinder with flat ends. A reinforcement ring is installed midway between the middle and each end, serving as an anchoring point for adjustable tiebolts. These bolts tie up the casing against axial forces caused by the steam. The inner casing is fastened to the outer casing, which is in turn fixed to the bedplate.

LP turbines

The LP turbines are double-flow turbines symmetrically built with axial-flow, reaction type blading. The main parts are:

- a welded outer casing
- a welded inner casing
- a forged and welded rotor
- three cast blade carriers
- two cast shaft seal holders, one at each end

An extensive modernization of the turbine plants of OL1 and OL2 was carried out during annual outages in 2005 and 2006. The photo shows the new reheater for OL1 being lifted into place.



Turbine plant

TURBINE

Nominal rating	MW	890
Live steam pressure	bar	67
Live steam temperature	°C	283
Live steam flow	kg/s	1,260
Rated speed	rpm	3,000
High Pressure turbine	Axial, 2-flow	
High Pressure control valves	4	
Low Pressure Turbine	Axial, 2-flow	
Low Pressure intercept valves	8	
Exhaust area	m ²	8 x 7.7
Last stage		
blade length	mm	930
overall diameter	mm	3,570

GENERATOR

Nominal rating	MVA	OL1 950, OL2 905
Power factor, nominal	cos	0.9
Rated voltage	kV	20
Voltage range	%	95–108
Frequency	Hz	50
Cooling, rotor/stator	water/air	
Exciter	brushless	

CONDENSER

Cooling surface	m ²	27,700
Cooling medium	sea water	
Cooling water flow	kg/s	29,200
Vacuum at full load	bar	0.05
Temperature rise	°C	13

FEEDWATER

Preheating stages	5	
Final feedwater temperature	°C	185

HP turbine

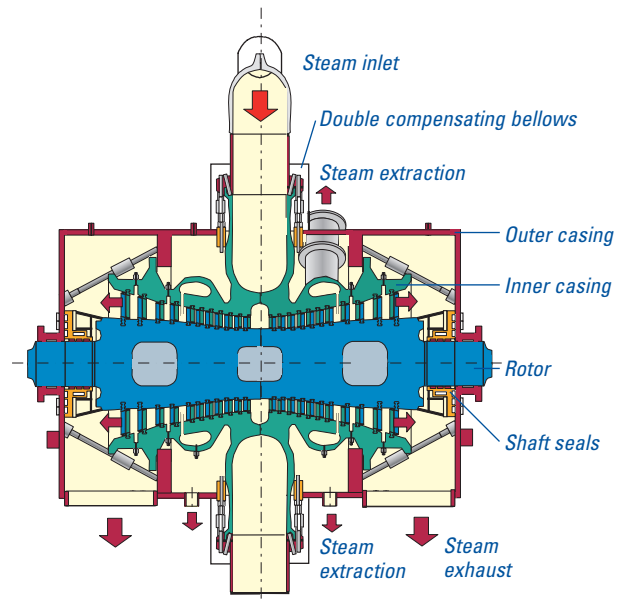

LP turbine

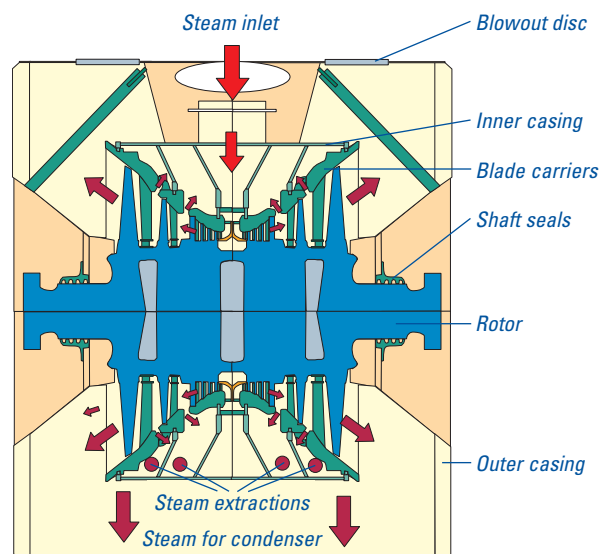

Steam enters the turbine from the separator/reheater units through crossover pipes fitted with low-pressure intercept valves.

The LP turbine is essentially of a dual casing design similar to that of the HP turbine.

The blade carriers are supported by the inner casing, which in turn is supported by brackets at the lower part of the outer casing. Steam is extracted between the blade carriers into the extraction space between the inner casing and the blade carriers, and then to the extraction ducts.

The lower half of the outer casing is designed to form a rectangular opening, which is welded to the condenser throat.

Each LP turbine is provided with two blowout discs, which protect the turbine against pressure in the event of other safety equipment failing to function.

The rotors, bladings, blade carriers and inner casings were replaced during annual outages between 1996 and 1998.

Generator

The turbine drives the rotor of the generator coaxially. All main parts in which electrical losses occur are directly water cooled. This includes the rotor winding and the stator winding as well as the winding terminals. The stator core is cooled by circulated air, which is then routed through an air/water heat exchanger. The cooling water is brought out to an external cooling and treatment plant.

All surfaces in contact with the water are made of stainless steel. The generator is equipped with a brushless excitation system with an AC exciter and rotating rectifiers. The diode rectifier is protected by fuses mounted in modules on the exciter rotor. This design allows for the inspection of the fuses during normal operation and easy replacement of fuse modules.

The generator is located outside the radiation shield of the turbine, and it is therefore fully accessible during normal operation of the plant.

Generator and exciter.



Condensate and feedwater

The turbine is equipped with a single-pass condenser, mounted across the longitudinal axis of the turbine. The condenser is divided into two shells, one for each pair of low pressure turbines. Each shell is fitted both with two water-boxes and with hotwells, which also act as condensate storage tanks.

The condenser is cooled by sea water. The sea water cooling pumps are of a vertical propeller type and they are located in the cooling water intake tunnel. The pumps supply the cooling water to a header before the condenser water boxes. Isolating and non-return valves are arranged in the inlet of the cooling water pipes, so that water can

be supplied to all of the water boxes even if one pump should fail.

The heating of the condensate and feedwater up to a temperature of 185 °C is carried out in five stages. Both the low pressure preheaters and the high pressure preheaters are divided into two half-capacity, parallel circuits, each equipped with a bypass system.

The condensate pumps are 4 x 33 % units. OL1 feedwater pumps are 4 x 25 % units and OL2 feedwater pumps are 4 x 33 % units. The pumps are driven by electric motors. The flow of the feedwater is controlled by adjusting the speed of the feedwater pumps with hydraulic couplings.

Condensate and feedwater system

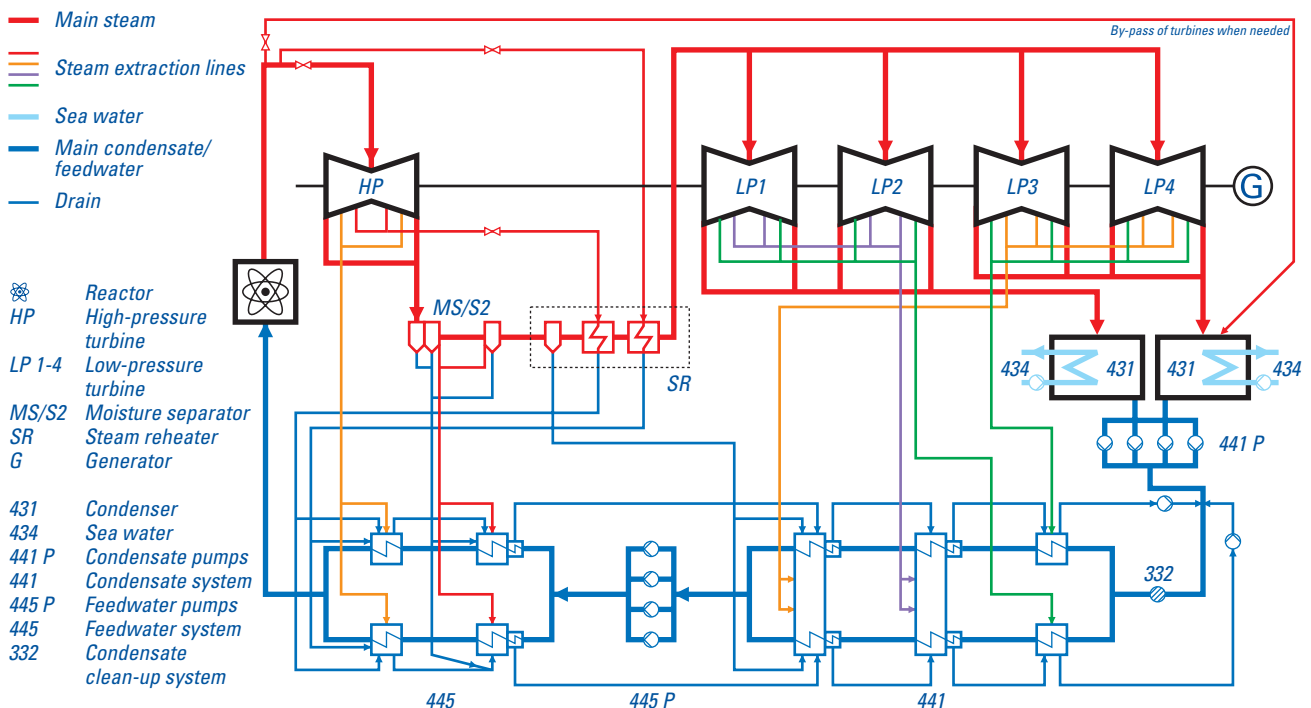

Sea water circuit

Cooling water is conveyed from the sea to both power plant units through underground cooling water ducts to a screening and pumping building, where the channel is divided into four intake channels. Each channel has a motor-driven intake valve, mechanical water treatment equipment, fine screens and basket filters. The main cooling water pumps pump the water into the condenser, from which it passes into the surge tank, and from there through an underground tunnel into the sea. The tem-

perature of the sea water increases by about 13 degrees as it passes through the condenser. Some 30 cubic metres of water per second are pumped through the condenser in both power plant units. The surge tank is a shock absorber in case the main cooling water pumps stop, to protect the condenser. If the intake of cooling water is blocked for some reason, cooling water can be taken from the extraction side, in which case the water flow in the cooling water channels will be reversed.

Sea water system

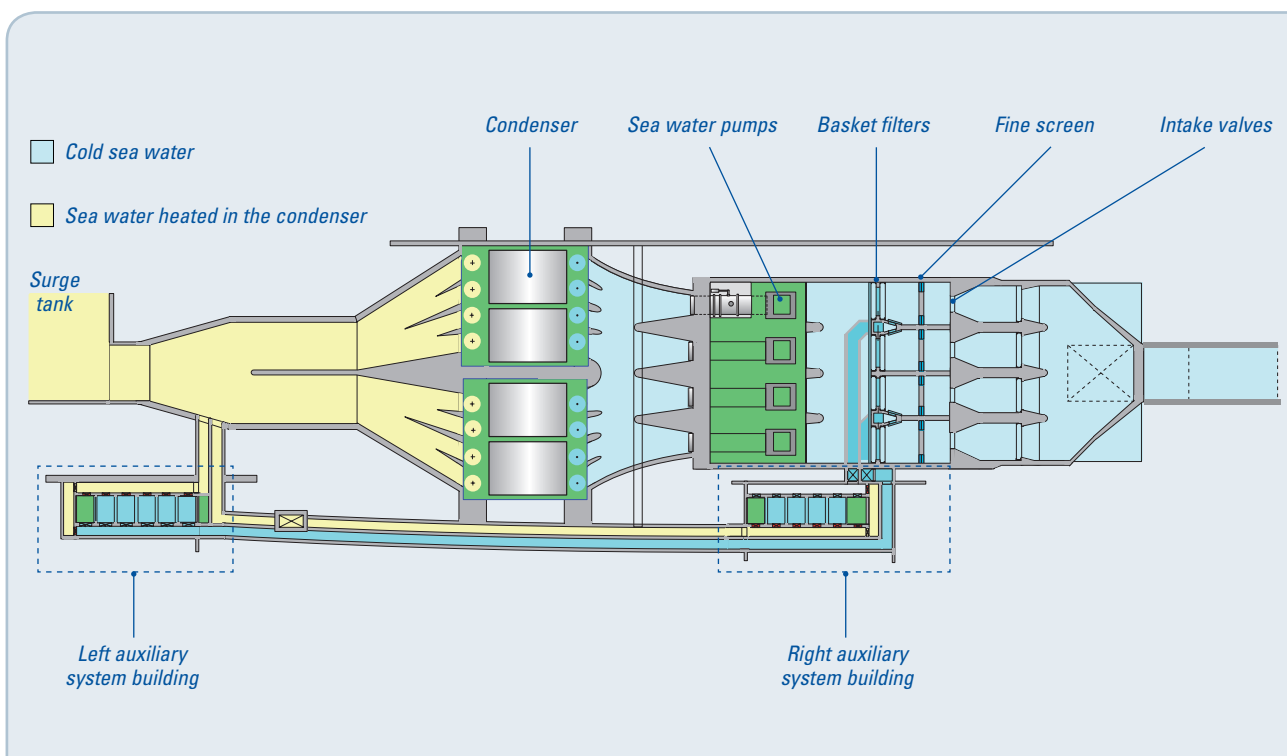

WATER CHEMISTRY

Steam-water circulation and cleanup systems

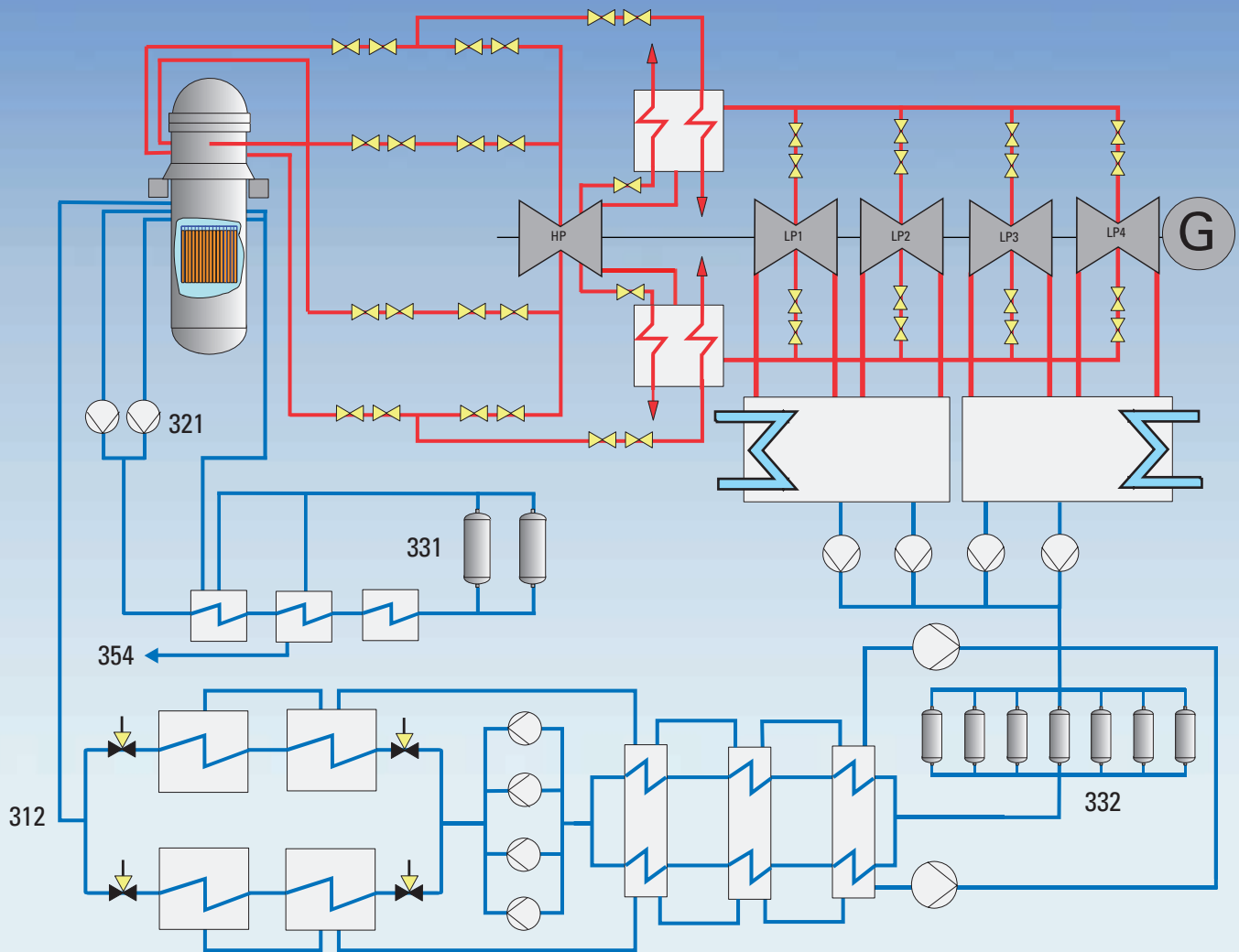

- 312 Feedwater system
- 321 Shutdown cooling system
- 331 Reactor water cleanup system
- 332 Condensate cleanup system
- 354 Scram system

- Steam
- Water
- Sea water

The primary circuit of a boiling-water reactor operates without chemical additives to the coolant, i.e. 'neutral water'. Electrical conductivity of the feedwater is kept as low as possible.

High reactor water purity contributes to reliable operation of the reactor. Keeping impurity levels low prevents crud deposits on the fuel rods and reduces the radioactive contamination of the primary system, thus reducing occupational radiation exposure. Reduction of particular impurities such as chloride also decreases exposure to stress corrosion.

The primary circuit water is treated by two independent, coordinated cleanup systems: the reactor water cleanup system and the condensate cleanup system.

The reactor water cleanup system comprises two ion exchanger units of radial flow, bed-filter type. Each unit is capable of producing the normal cleanup flow, so that the flow can be doubled when necessary.

The cleanup flow is generated by one pump in the shutdown cooling system, through two regenerative heat exchangers and one cooler, to one of the ion exchangers, and returns to the reactor via the regenerative heat exchangers. A portion of it flows through the scram system, purging and cooling the control rod drives.

The condensate cleanup system, located prior the reheaters, comprises seven parallel-coupled trains with rod-type precoat filters. These filters clean the feedwater returning from the condenser to the reactor both mechanically and with a thin ion-exchange resin layer on the surface of the filter rods.

Measuring metal concentrations in process water using an ICP optical emission spectrometer.

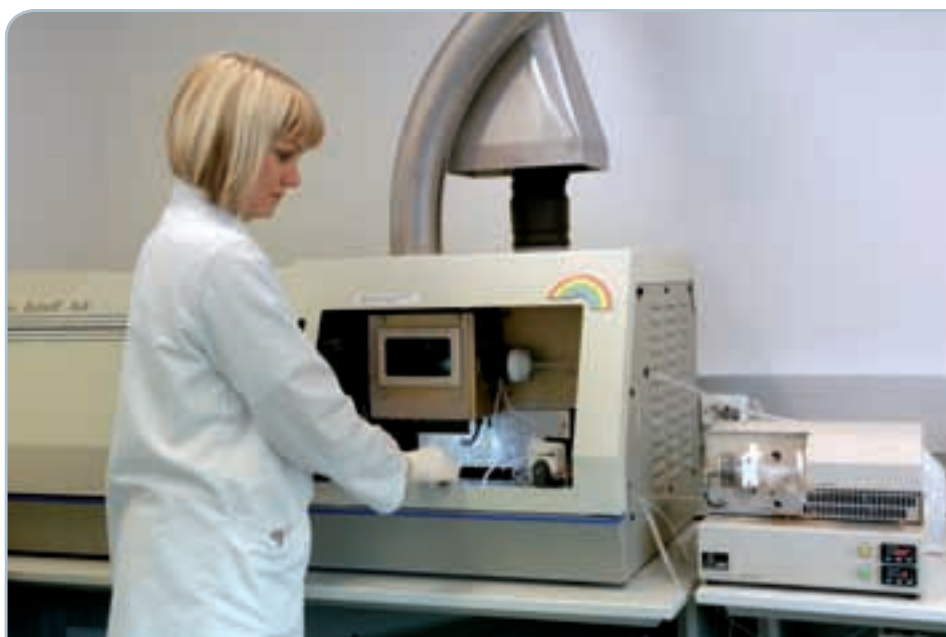



INSTRUMENTATION AND CONTROL SYSTEMS



The instrumentation and control systems consist of: instruments that measure processes; various automatic and manual control and regulation systems; and systems which display and record measurements and event information.

In keeping with the safety principles observed of the power plant, all principal instrumentation systems and their controls are built as parallel component systems. The control logic in safety-critical systems relies on the 2-out-of-4 principle, which means that the protection system is automatically triggered if two out of the four monitoring systems issue an alert to that effect. The principal functions can also be launched and completed manually.

The principal power plant control systems, which include regulation of reactor pressure and feedwater, have triple redundancy. In the power control system, measurement of power at the generator and of the neutron flux is used as the basis for regulating the speed of the main circulation pumps of the reactor.

The power plant processes are centrally monitored and controlled in the control room. The state of the various processes is displayed on numerous screens and with meters and indicator lights. Process control is mainly done through computer terminals and control switches. The control boards behind the control desks are used for controlling and observing certain reactor functions and the operating of the electricity supply and switchgear. The

power plant is automated to such a high extent that normal running requires minimal control measures from the control room operators. The control and process equipment in the principal systems are divided into four independent systems.

Most of the process measurements are linked to a process computer system with double redundancy. The computer terminal screens help the operators monitor the processes through a variety of general, status, trend, event and alert displays. Display pages can be selected according to the state of operations. There is also a large screen for displaying the status of the turbine plant. The process computer system is further used for long-term storage of measurement and event data. Two parallel computers are used for calculations involved in the monitoring of the reactor core.

There is a dedicated measurement computer for recording, at a 100 Hz sampling rate, certain data of particular interest for evaluating process transients or disruptions.

The power plant has numerous further analogue and computer-based control and monitoring systems, such as the neutron flux measurement and calibration systems, the reactor fuel loading monitoring system, radiation measurement systems for the power plant and its environment, the control rod position indicator system, the system monitoring vibrations in the turbine and the shaft and bearings of the generator, the turbine protection system, and so on.

Operational levels according to the safety principles of the automation system

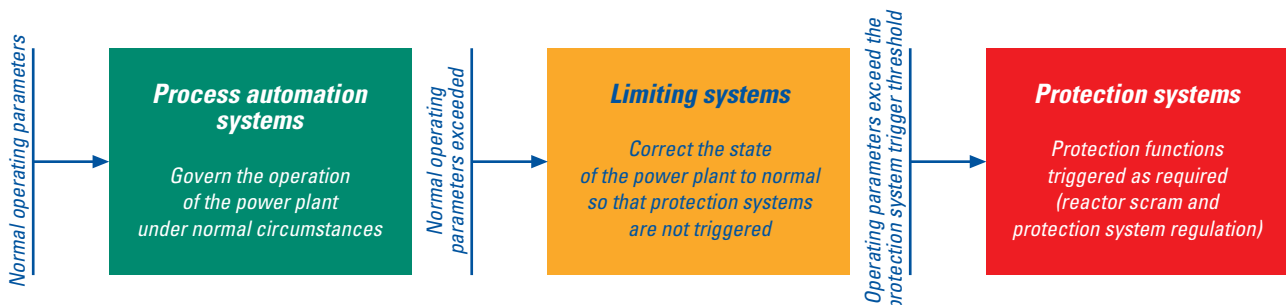

ELECTRICAL POWER SYSTEMS

- 421 Generator
- 611 Main Transformer
- 612 Start-up transformer
- 613 Plant transformer
- 621 Main grid 400 kV
- 622 Start-up grid 110 kV
- 642 General 6.6 kV system
- 653 Diesel generator
- 662 Diesel-backed 660 V system
- 664 UPS-backed 380/220 V system
- 665 UPS-backed 220 V system

Plant distribution network and external grid connections

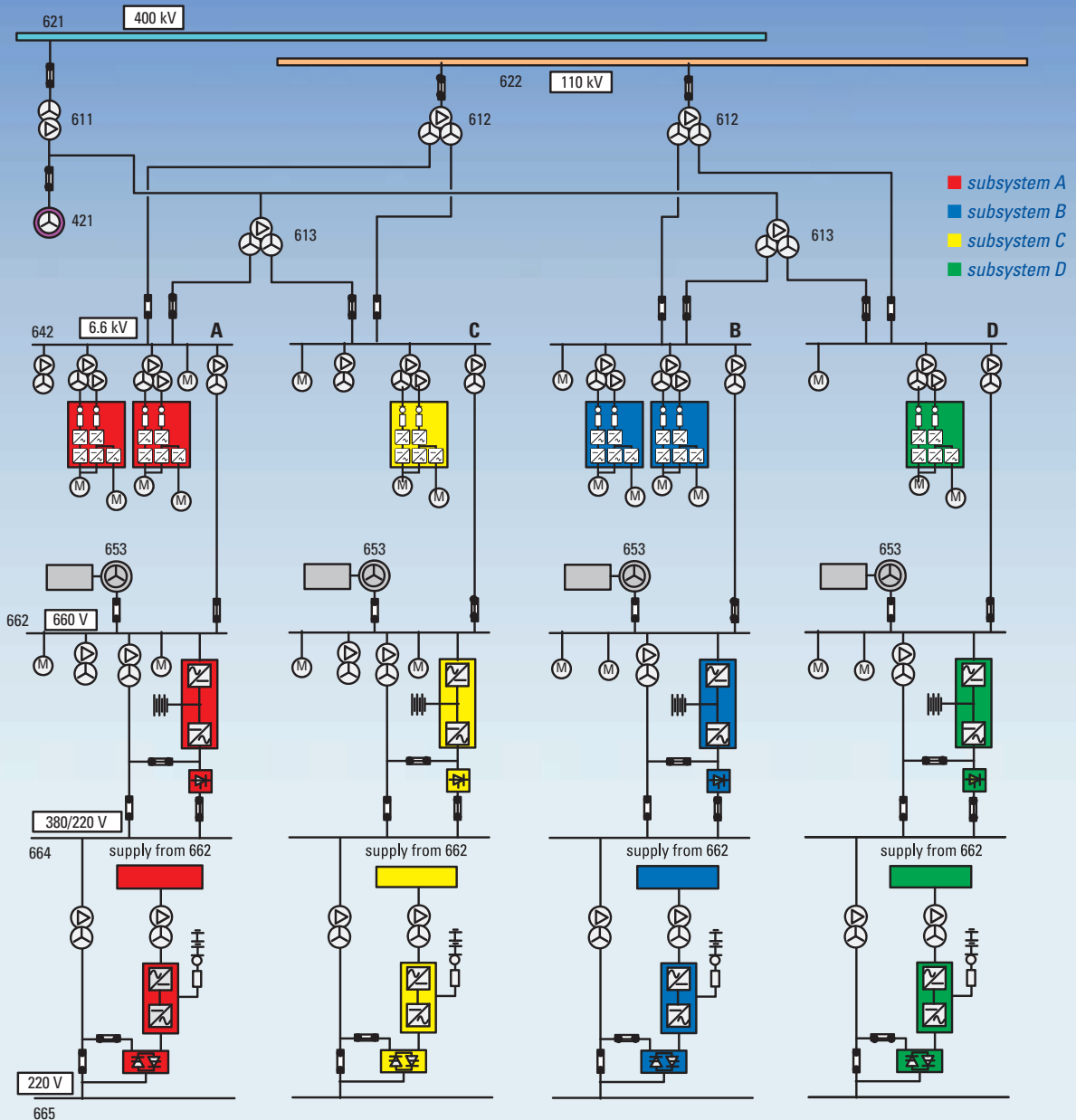

The electrical power systems fall into two categories, one related to the generating and transmission of power to the external grid and the other to the (internal) supply of power to plant unit both under normal circumstances and in case of disruption.

The former consists of the generator, the generator busbars, the generator breaker, the main transformer and the 400 kV overhead line and switchyard. The latter includes the auxiliary transformers and the internal power distribution systems.

The generator buses are made up of one-phase busbars with grounded metal enclosures. Each one-phase busbar has a single-phase breaker. The busbars also include the necessary earthing isolators, voltage and current transformers and capacitors.

The main transformer is a three-phase forced oil/forced air cooled unit.

The internal power distribution system is divided into safety-related and non-safety-related systems, in accordance with the requirements on the process systems to be supplied with power. Power is normally taken from the generator through two plant transformers, but during annual outages or generator disruption, power is taken from the 400 kV grid or from the 110 kV grid through the start-up transformers.

The internal distribution network is divided into four parallel subsystems, which are independent and physically separated from one another (A, B, C and D).

DC systems and battery-backed AC systems supply power to control systems and valve motor drives, among other things.

Four diesel generators provide the on-site standby power supply.



SAFETY

Three elements are required to ensure reactor safety under all circumstances: 1) control of the chain reaction and the power it generates, 2) fuel cooling even after the chain reaction is shut down, i.e. removing afterheat, 3) isolating the radioactive substances from the environment.

Safety rests on two main principles: 1) five layers of isolation for radioactive substances: ceramic fuel, gas-tight fuel rod, gas-tight pressure vessel, gas-tight reactor containment, and reactor building; and 2) the defence-in-depth safety principle.

Multiple barriers

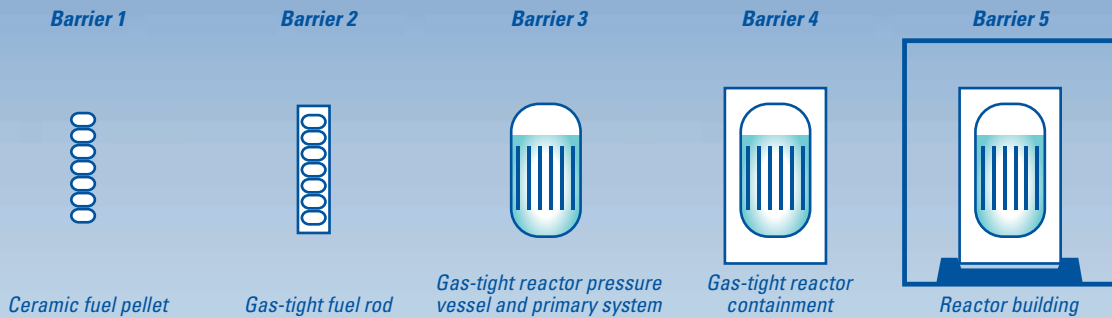

One of the main principles of nuclear safety is the arrangement of multiple barriers between radioactive materials and the environment.

Examples of the defence-in-depth way of thinking

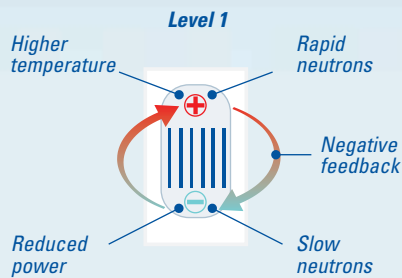

As the reactor temperature rises, its power is reduced, because the increased boiling produces less slow neutrons and so slows down the chain reaction.

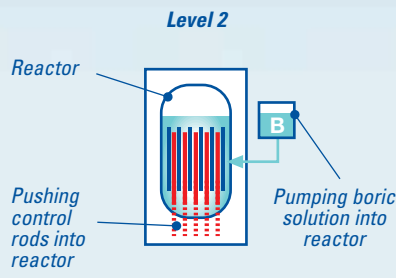

The reactor can be closed down in a few seconds by means of two systems with different operating principles.

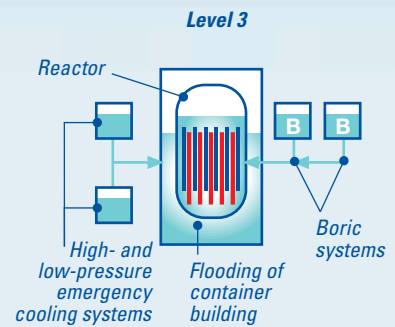

In an accident situation the safety systems prevent or alleviate the consequences.

Safe use

The basic principle in nuclear safety is that radioactive substances must not be released into the environment. There are multiple layers of safety arrangements to prevent this.

The Olkiluoto nuclear power plant units have multiple safety systems operating on a variety of principles to detect and quickly control any disruptions. This arrangement is based on the defence-in-depth safety principle. All safety-critical functions are provided with several redundant parallel systems and devices, and high quality standards and sufficient safety margins are applied to the design of all equipment and functions.

The safety arrangements are based on the requirement that no user errors or equipment malfunctions, even if several co-occur, can in and of themselves cause a serious accident. The critical safety systems must be able to function even if any given device in the system is incapacitated or if any given safety-related device is off line at the same time because of repairs or maintenance.

To minimize the risk caused by the radioactive fuel, there are several concentric protection zones. The first barrier against the release of radioactivity is the fuel pel-

let. Made of uranium dioxide, it retains the fission products. The second barrier is the metal tube enclosing the fuel rod, and the third is the reactor pressure vessel. The fourth barrier is the gas-tight containment surrounding the reactor, and the fifth and outermost barrier is the massive reactor building.

High-level safety culture

TVO and its personnel are committed to a high-level safety culture whose principles include handling every matter according to its safety significance and aiming at a high level of reliability and production security in all aspects of operations. The high-level safety culture is typified for instance by transparent reporting on any nonconformities, continuous development of operations, and uncompromising following of instructions. Safety and safety factors always take priority over economic targets. The main aim of the personnel at the Olkiluoto nuclear power plant is to ensure safe operation of the power plant units under all circumstances. TVO is active in its efforts to prevent the emergence of disruptions which might affect safety or usability. TVO follows a policy of continuously and methodically promoting its high-level safety culture.

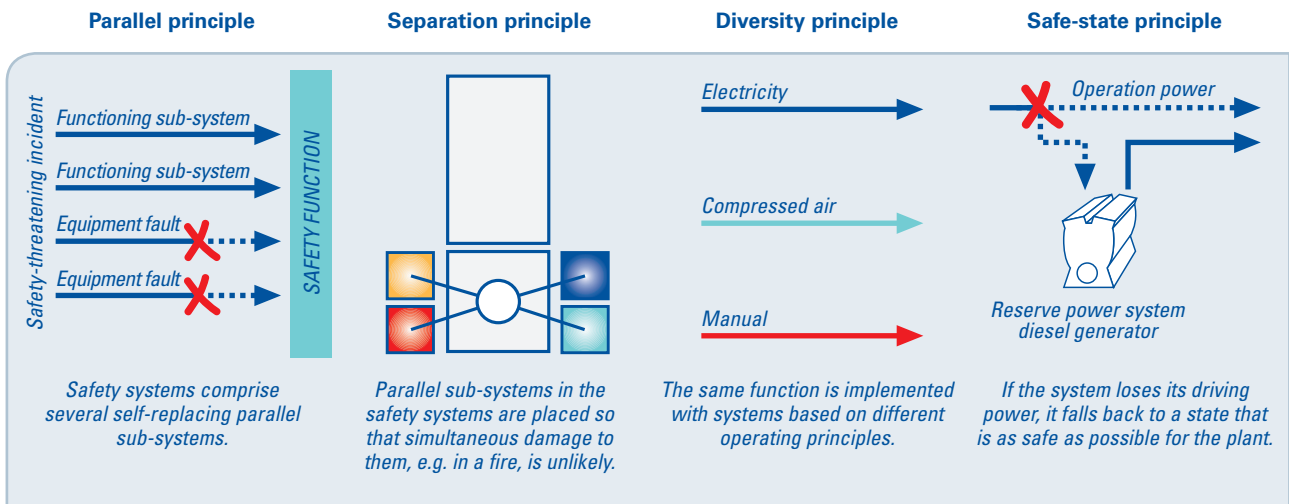

Emergency cooling systems of the plant unit

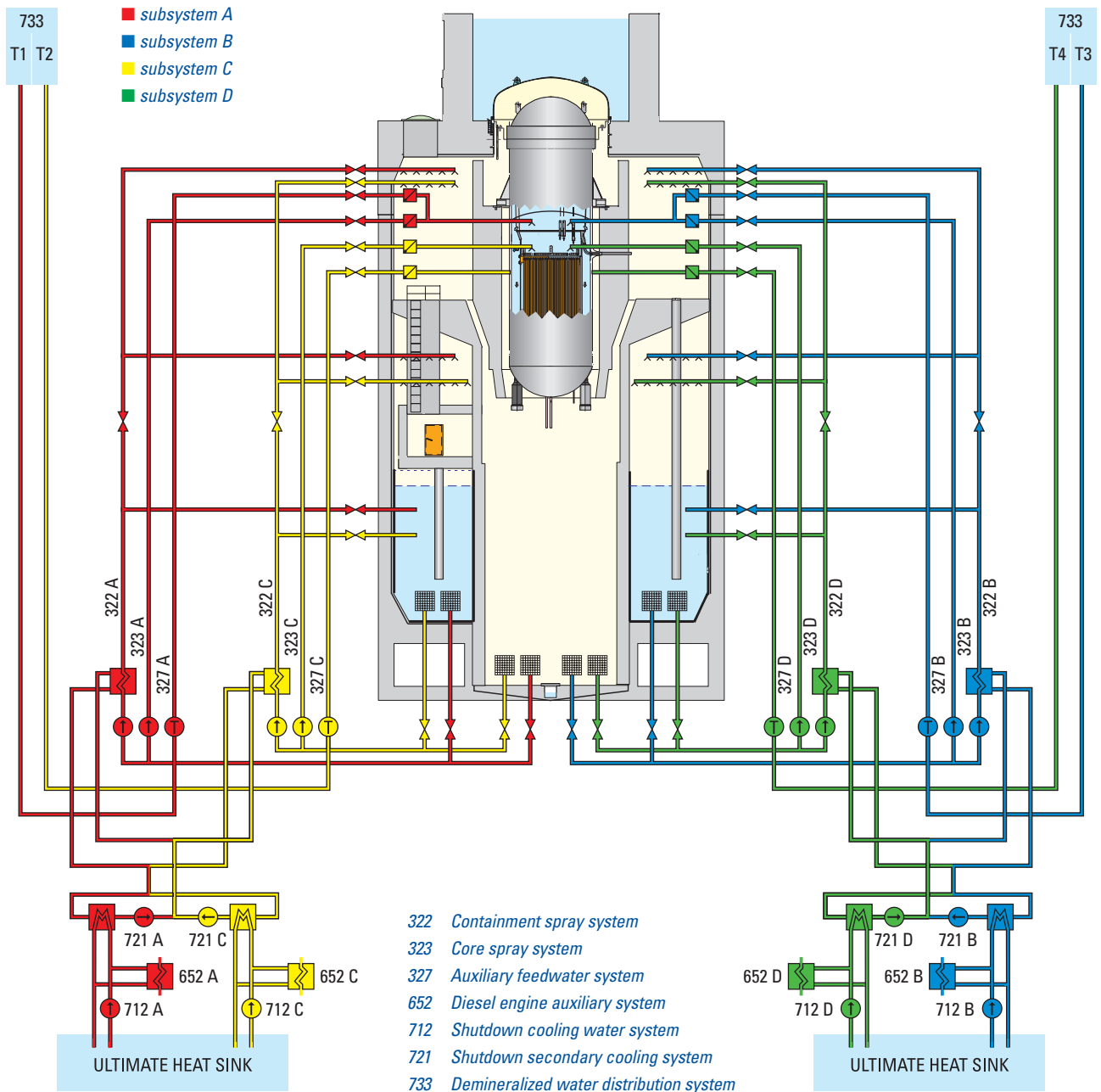

Emergency core cooling system

Emergency core cooling is provided by two different systems – the auxiliary feedwater system and the core spray system. The auxiliary feedwater system operates as a high pressure coolant injection system. It has sufficient capacity to keep the core flooded following the rupture of any of the nozzles at the bottom of the reactor vessel.

The core spray system operates at low pressure. It feeds spray water into the reactor when the pressure drops as a result of ruptures in the pipes connected to the cylindrical part of the reactor vessel above the top of the core.

Both systems, with associated auxiliary systems which perform emergency cooling functions, are divided into four independent subsystems, of which two are required to cope with an accident resulting in a loss of coolant.

This allows testing and repair to be carried out without limiting plant operation.

Each subsystem incorporates separate pumps, valves etc., and power supply from correspondingly separated standby power diesel generators. The auxiliary feedwater system draws its water from special storage tanks, one separated tank volume for each of the subsystems.

The core spray system draws water from the condensation pool inside the containment. The water of this pool is cooled by the containment vessel spray system, which in turn is cooled by the sea water system via an intermediate fresh water system.

The condensation pool heat sink can accept decay heat for several hours after reactor shutdown without any external containment cooling.

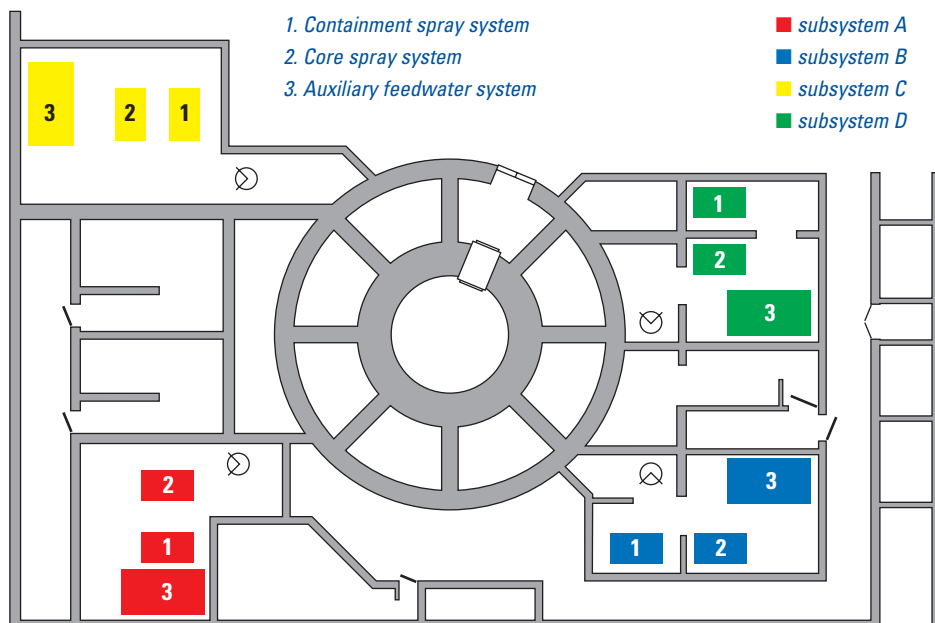

OFF-GAS SYSTEM

Off-gas system limits the emission of radioactive noble gases from the plant units.

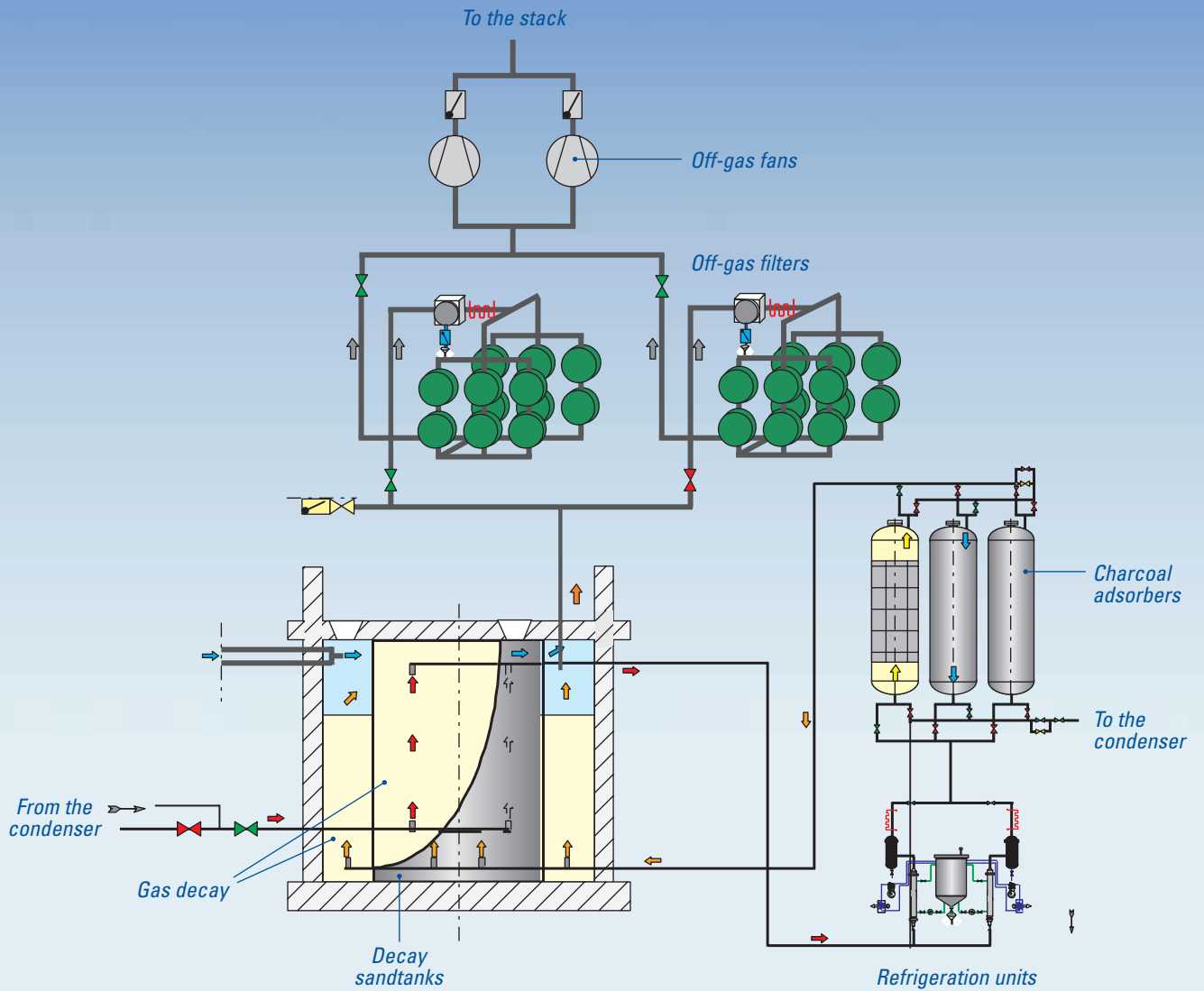

The off-gas system limits the emission of radioactive noble gases from the power plant units. The system includes a decay phase and an adsorption phase. The decay phase consists of two sand tanks, and the adsorption phase consists of three active charcoal filters.

The sand tanks slow down the progress of off-gas, allowing short-lived nuclides time to decay. Between the sand tanks are the active charcoal filters and two parallel coolers to reduce humidity in the off-gas. The active charcoal absorbs radioactive substances, which are periodically flushed back into the condenser. Two of the three filters are in use at any given time, one being connected

to the off-gas flow and the other being used for flushing back to the condenser. Filters are exchanged according to a predetermined plan.

After passing through the active charcoal filters, the gas is conveyed through the second sand tank and then through the off-gas filter to the stack. The off-gas filter removes 99.9 % of any iodine content in the off-gas.

The radioactive emissions into the air from the Olkiluoto power plant units are well below the maximum allowable limits set by the authorities, being no more than a few tenths of one per cent of those maximums.

The air flow in the ventilation stack is sampled and measured for the rates of radioactive releases into the atmosphere.



WASTE TREATMENT SYSTEMS

Liquid waste treatment

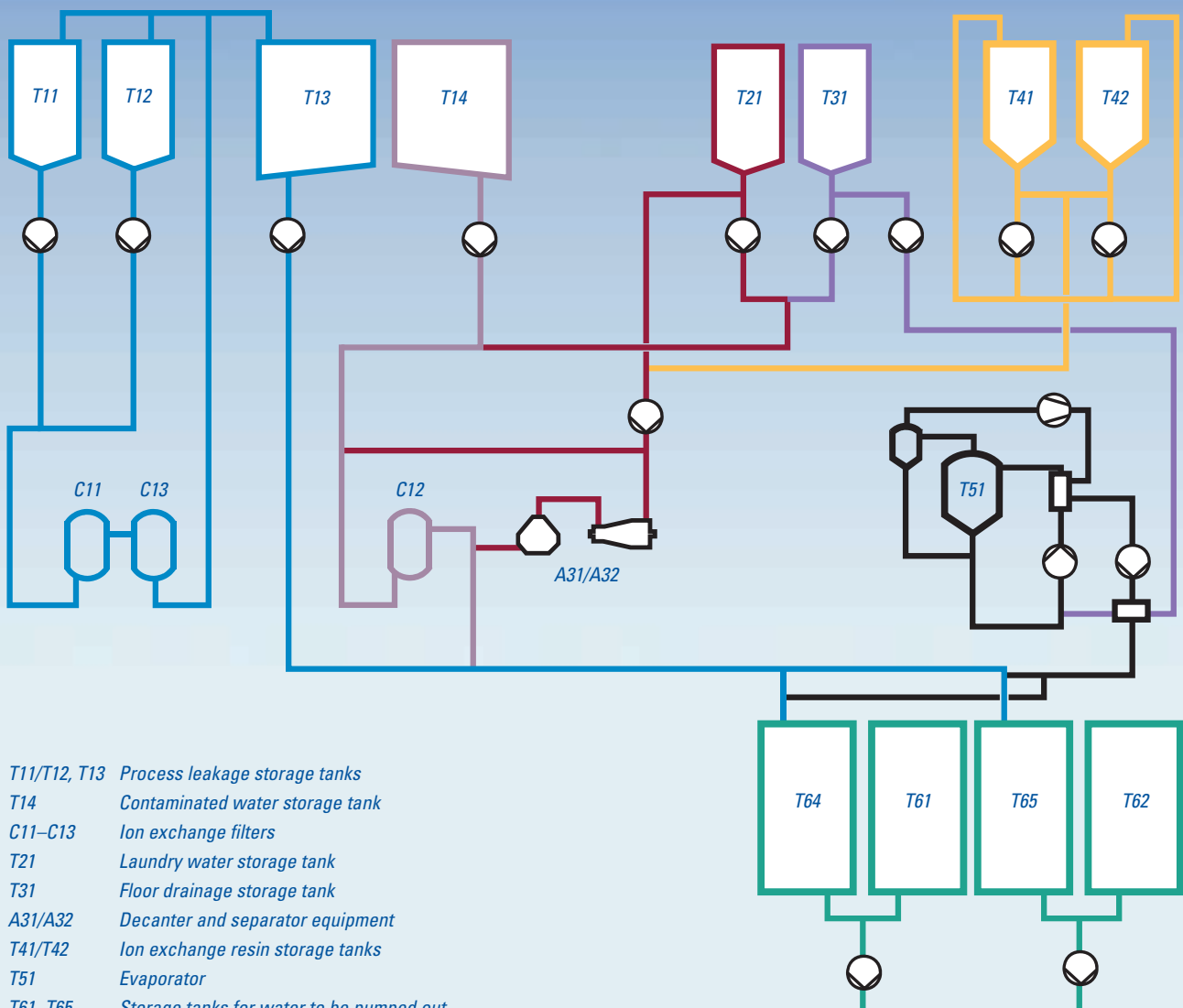

- T11/T12, T13 Process leakage storage tanks
- T14 Contaminated water storage tank
- C11–C13 Ion exchange filters
- T21 Laundry water storage tank
- T31 Floor drainage storage tank
- A31/A32 Decanter and separator equipment
- T41/T42 Ion exchange resin storage tanks
- T51 Evaporator
- T61–T65 Storage tanks for water to be pumped out

Process waste treatment systems

The process waste treatment systems include equipment for handling both liquid and solid process waste.

Liquid process waste is collected in a number of systems at the power plant and pumped into dedicated reception tanks in the waste treatment plant. Chemically pure water is filtered and passed through ion exchangers and then reintroduced into the power plant processes.

Water from floor drainage and the 'active laundry' and other water with particle impurities are cleaned by spinning, filtering, ion exchange or evaporation and then pumped into the sea.

The solid waste treatment system includes equipment for handling, sorting and compacting low-level radioac-

tive waste and for solidifying intermediate-level radioactive waste.

The low-level radioactive waste includes the protective material, cleaning rags, etc., used in maintenance and repair procedures. The low-level radioactive waste is sorted and packed into steel drums for final deposit. Before being transported to the repository, the drums are compacted to about one half of their original volume.

The intermediate-level radioactive waste includes the ion exchange resin created in cleaning process water and process waste water, and the evaporator concentrate. These are dried and mixed into bitumen before being packed into steel drums.

The ion exchange resins and evaporator concentrate created in the cleaning of process water and process waste water are mixed into bitumen and poured into steel drums. The photo shows the bituminization process.





ELECTRICITY TRANSMISSION



Main transformer

The main transformer in each of the power plant units has a nominal output of 1,000 MVA (mega-volt-amperes). The transformers are three-phase, forced oil/forced air cooled units. The 20 kV voltage produced by the generator is transformed by the main transformers to 400 kV before supplying into the national grid. A line conveys the power from the transformers to the Fingrid 400 kV sub-station, which is further connected to the national grid.

The power generated by TVO is distributed by the owners, about half to industry and the other half to services, agriculture and households.

Power transmission

The Finnish power system consists of power plants, the national grid, local power networks, distribution networks and consumers. Most of the electrical power used in Finland is transmitted through the national grid maintained by Fingrid Plc. The national grid includes some 4,100 km of 400 kV power lines, some 2,350 km of 220 kV power lines, and some 7,500 km of 110 kV power lines.

Electrical power is transmitted from the power plant units to the Fingrid 400 kV sub-station and from there to the national grid.



TRAINING SIMULATOR

Training simulator



In-house training for TVO personnel is mainly given at the company training centre at Olkiluoto. The most important single element in the training centre is the plant-identical training simulator, which includes a full-sized copy of the OL1 control room together with a computer system which simulates the power plant processes. The computers and models simulate all control room functions and are identical with real plant behaviour.

The simulator is a vital tool in the training of new operators, because it enables them to practise controlling and monitoring the power plant without interfering with its actual normal operations.

For each simulator exercise, a program is devised which contains different situations that may occur. The trainees must know how to respond in these situations. If necessary, the exercise can be repeated to correct mistakes. The simulator also enables personnel to practice exceptional situations such as disruptions and accidents. All shift supervisors and operators take at least two weeks of simulator training every year.

The simulator can also be used to develop, test and train new control room functions before they are introduced in the power plant units themselves.

Turbine control displays. Using the simulator, operators can practise controlling the power plant without interfering with its actual normal operations.



Technical data

General

Reactor thermal power	MWth	2,500
Electrical output, net	MWe	860
Electrical output, gross	MWe	890
Reactor steam flow	kg/s	1,260
Reactor operating pressure	bar	70
Feedwater temperature	°C	185

Core

Number of fuel assemblies		500
Total fuel weight	tnU	85–90
Core diameter (equiv.)	mm	3,880
Core height	mm	3,680

Fuel

Fuel rods per assembly		91–96
Fuel rod outer diameter	mm	approx. 10
Cladding material		Zry-2
Weight of fuel assembly (incl. channels)	kg	approx. 300
Uranium fuel per assembly	kgU	175

Control rods

Number of control rods		121
Absorber length	mm	3,650
Total length	mm	6,380
Absorber material		B ₄ C and Hf

Reactor pressure vessel

Inner diameter	mm	5,540
Inner height	mm	20,593
Wall thickness, carbon steel (ASME A533B, A508Gr2)	mm	134
Thickness of stainless steel liner	mm	5
Design pressure	bar	85
Operation pressure	bar	70
Design temperature	°C	300
Operation temperature	°C	286
Weight of vessel	ton	524
Weight of cover	ton	107

Recirculation pump (Normal power operation, 6 pumps)

Rated speed	rpm	approx. 1,350
Head	m	approx. 25
Motor power	kW	740

Turbine plant**TURBINE**

Nominal rating	MW	890
Live steam pressure	bar	67
Live steam temperature	°C	283
Live steam flow	kg/s	1,260
Rated speed	rpm	3,000
High pressure turbine	Axial, 2-flow	
High pressure control valves		4
Low pressure turbine	Axial, 2-flow	
Low pressure intercept valves		8
Exhaust area	m ²	8 x 7.7
Last stage		
blade length	mm	930
overall diameter	mm	3,570

GENERATOR

Nominal rating	MVA	OL1 950, OL2 905
Power factor, nominal	cos	0.9
Rated voltage	kV	20
Voltage range	%	95–108
Frequency	Hz	50
Cooling, rotor/stator	water/air	
Exciter	brushless	

CONDENSER

Cooling surface	m ²	27,700
Cooling medium	sea water	
Cooling water flow	kg/s	29,200
Vacuum at full load	bar	0.05
Temperature rise	°C	13

FEEDWATER

Preheating stages		5
Final feedwater temperature	°C	185

Power supply**MAIN TRANSFORMER**

Nominal rating	MVA	1,000
Rated voltage	kV	412/20
Cooling form	OFAF	

PLANT TRANSFORMERS (2)

Nominal rating	MVA	30/16/16
Rated voltage	kV	20/6.9/6.9

STARTUP TRANSFORMERS (2)

Nominal rating	MVA	40/25/25
Rated voltage	kV	115/6.9/6.9

AUXILIARY POWER SUPPLY

General systems	kV ac	6.9/0.69
Diesel-backed	kV	0.69
Diesel generators (4)	MVA	2
Battery-backed	V dc	24–400



Teollisuuden Voima Oy
Olkiluoto
FI-27160 EURAJOKI, FINLAND
Tel. +358 2 83 811
Fax +358 2 8381 2109
www.tvo.fi

Teollisuuden Voima Oy
Töölönkatu 4,
FI-00100 HELSINKI, FINLAND
Tel. +358 9 61 801
Fax +358 9 6180 2570

Teollisuuden Voima Oy
Scotland House
Rond-Point Schuman 6
BE-1040 BRUSSELS, BELGIUM
Tel. +32 2 282 8470
Fax +32 2 282 8471

Subsidiaries:

Posiva Oy
Olkiluoto
FI-27160 EURAJOKI, FINLAND
Tel. +358 2 837 231
Fax +358 2 8372 3709
www.posiva.fi

TVO Nuclear Services Oy
Olkiluoto
FI-27160 EURAJOKI, FINLAND
Tel. +358 2 83 811
Fax +358 2 8381 2809
www.tvons.fi